



SYSTRA

WHO WE ARE

THE LEADING COMPANY IN TUNNEL DESIGN

For 65 years, SYSTRA has designed and rehabilitated underground structures, including railway stations, tunnels, hydroelectric power plants and mines around the world. To meet our clients' needs, we optimise both operating and maintenance performance while reducing costs and delivery times.

We are a global company, a leader in planning, design, rehabilitation and construction for road and rail underground infrastructures.

We are bringing expertise throughout the asset lifecycle from pre-feasibility, through risk engineering and ventilation systems to post maintenance and asset management.

OUR KEY FIGURES



55+km

the longest rail tunnels
in the world

*BRENNER AND
LYON-TURIN BASE TUNNELS*



More than **4,000km**
of tunnels
worldwide



+750 experts
deeply specialised in
tunnelling and
underground structures

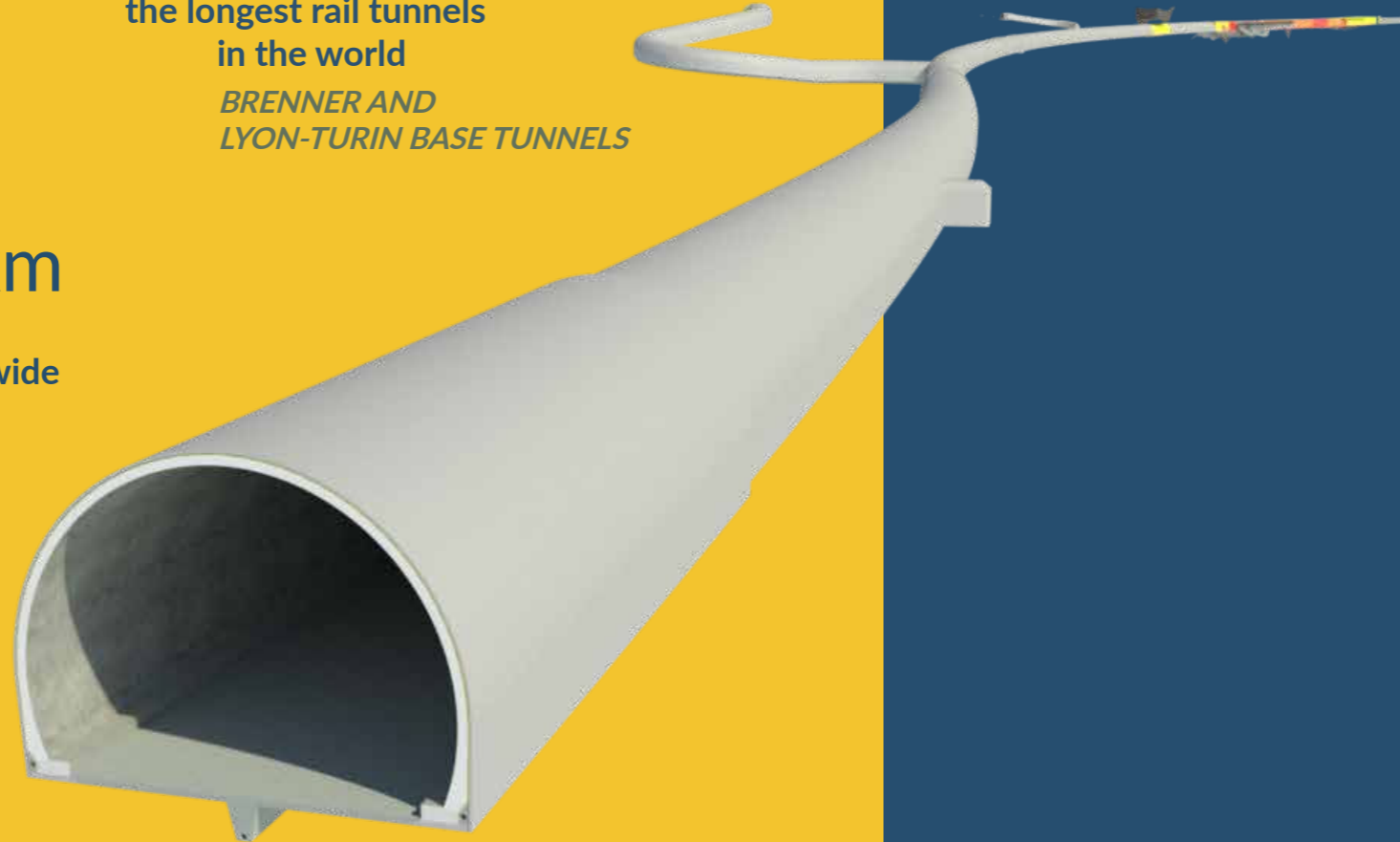

OUR MARKETS

Conventional & High-Speed Rail

Metro & Tramway

Road

Water

Mining

Hydroelectric

TUNNELS & UNDERGROUND

TEAMING UP WITH YOU TO SATISFY EVERY CLIENT

Our capacity for multi-site production guarantees operational excellence and in-depth knowledge of a wide range of local contexts.

By mobilising international experts on our projects, we assemble the best possible teams for the delivery of the projects, achieving and exceeding client expectations in terms of technical excellence and efficiency.



OUR OFFICES

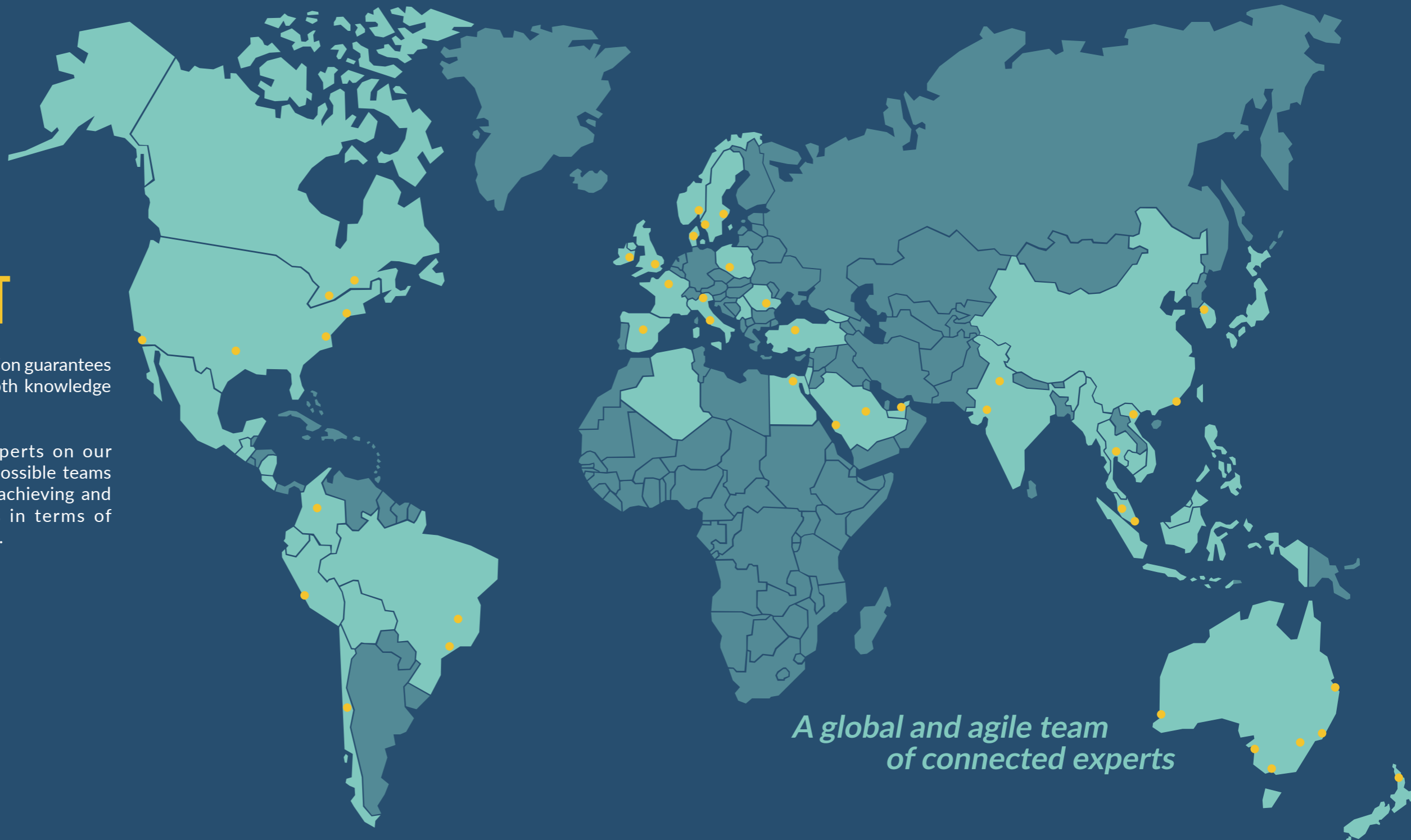

*A global and agile team
of connected experts*

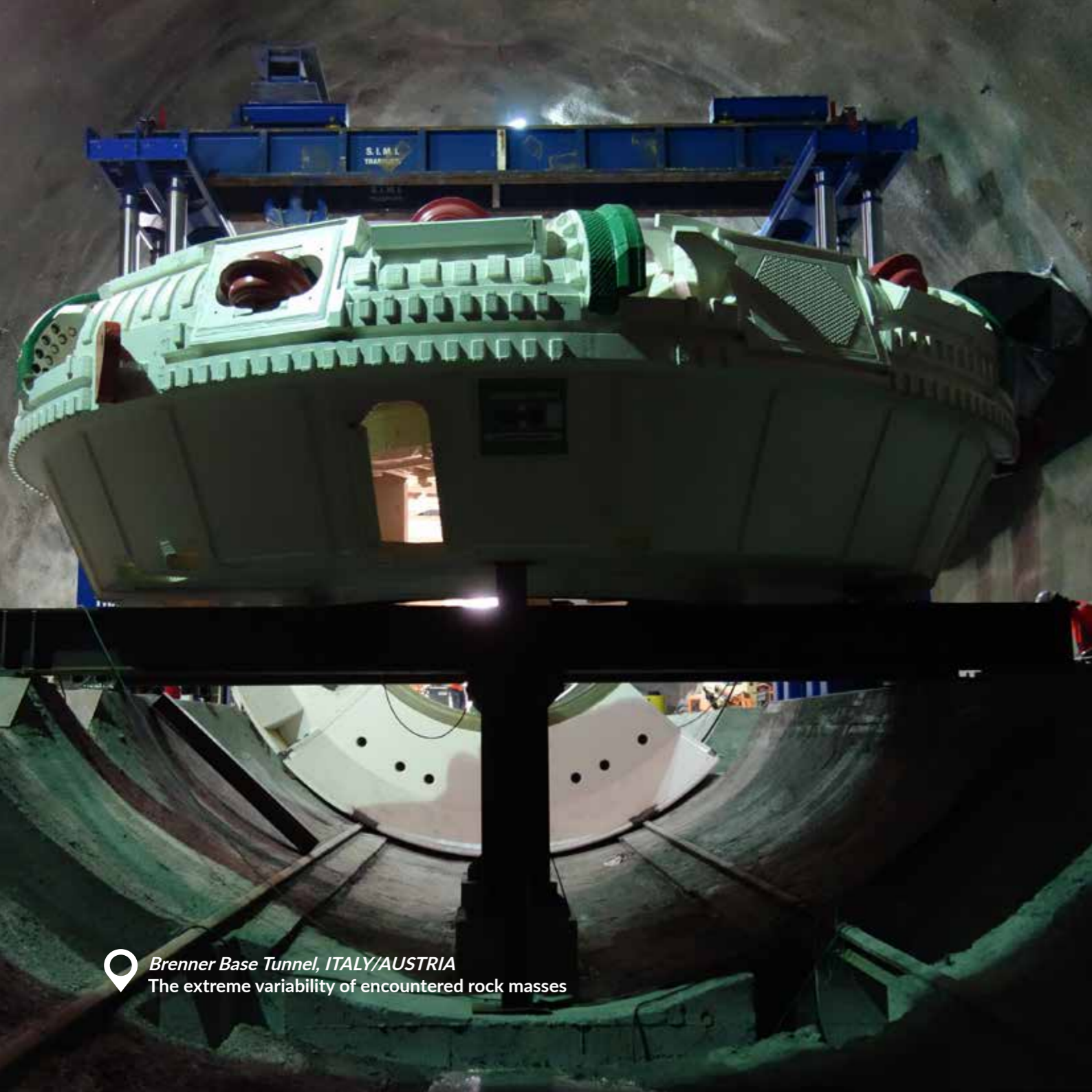

Brenner Base Tunnel, ITALY/AUSTRIA
The extreme variability of encountered rock masses

UNDERSTANDING YOUR NEEDS

PERFORMANCE FOR EVERY TYPE OF UNDERGROUND SOLUTION

Dense surface environments, topographical challenges and limited space are making underground solutions increasingly attractive, especially in urban areas. They offer an effective, safe, and sustainable answer to society's emerging needs: decongestion of major roads, public transport, roads for supply chain and organisation, mobility, and mining.

Optimise the use of underground spaces, whatever their geology or environment. You can count on our vast experience of urban tunnels in difficult geological contexts and sensitive built-up areas. We offer you design of all types of underground structures, from machine bored tunnels to NATM (Drill & Blast) tunnels and cut and cover types in any kind of soil/rock.

**PROVIDING
SPECIALISED VALUE
ENGINEERING SERVICES
TO SOLVE THE
EXTRAORDINARY
CHALLENGES EMERGING
FROM BOTH
CONVENTIONAL AND
MECHANISED
EXCAVATION TECHNIQUES**

Understanding how the ground behaves is our core expertise

The soil is usually the greatest challenge for tunnelling. Our ability to model complex interaction between the ground and structures in each project offers you a unique customised solutions.

We have experience of geological settings and climates across the world. Our engineers rely on interactive and geo-referenced platforms, to manage and model ground data, the project, and the surrounding built environment.

Geotechnical data from SYSTRA projects all around the world is stored and shared in the GIS web-application GEOShare.

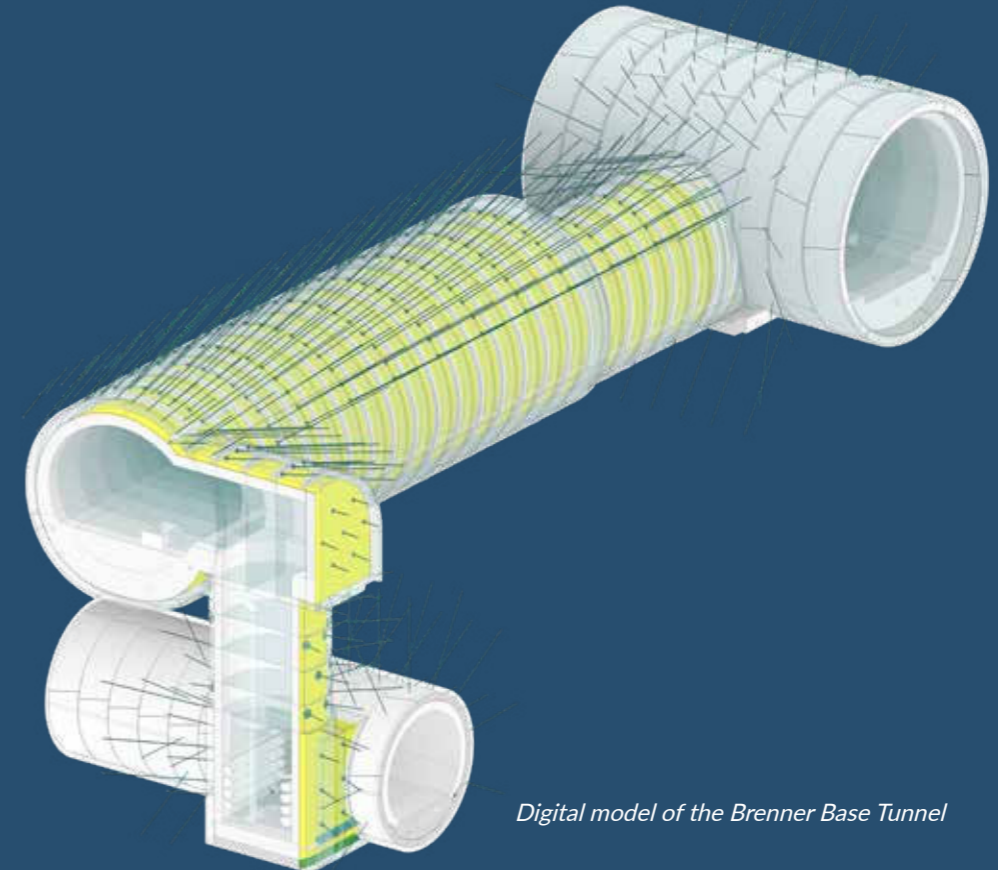

Digital model of the Brenner Base Tunnel

Successful underground projects rely on the selection of appropriate construction methods

Our teams provide a Unique Added Value at every step of the project lifecycle, at qualification stage, tender stage or project execution stage, to help you stand out from your competitors and deliver successful projects to the final client.



Risk Management is at the centre of the design process from the preliminary phases to the maintenance

In all underground projects unforeseen ground conditions can always occur. Therefore, you should choose an expert in minimising the risks and correctly managing the residual risks, as this is the key to a successful tunnel project.



Assisting you in Risk Management

Responding to your requirements, from the very beginning of the tendering stage, means that you can rely on our assistance in developing a proper risk matrix and identifying the most suitable mitigation solutions for the project. This develops in the contingency plan that results in an effective pricing tool.

OUR SERVICES

To give you the most from our value proposition, we have an in-depth understanding of what is at stake during the entire project lifecycle.



Fréjus tunnel, FRANCE

DESIGN

- Architecture & Landscape design
- Concept design
- Detailed design
- Expertise
- Feasibility studies
- Geological, Geotechnical & Hydrogeological studies
- Preliminary design
- Project Development

PROJECT MANAGEMENT

- Commercial Management
- Delivery Partner
- Project monitoring
- Project planning
- Project risk assessment

MEP DESIGN

- CFD Simulation
- Commissioning support
- Complete Safety System Design
- Definition of ventilation strategies
- Ventilation and Fire safety

VALUE ENGINEERING

- Advance FE Simulation
- Asset Management
- Implementation of new technologies
- Project optimisation

CONSTRUCTION MANAGEMENT

- Construction design
- Construction monitoring
- Construction planning
- Construction risk assessment
- Project Engineering
- Technical Assistance

BIM MODELLING

- Civil works
- Finishes & MEPs
- Road & Terrain

INDEPENDENT CHECK

- Code compliance
- Project Constructability
- Technical content

TENDER ASSISTANCE

- Communication strategy
- Illustrative Videos
- Professional graphic support
- Schematics & Renderings

ASSESSMENT & REPAIR

- Condition Evaluation and Inspection
- Design or Repair Works
- Rehabilitation
- Structural Assessment



Lyon metro line B, FRANCE
99.9% of excavated material recovered

OUR EXPERTISE & STRENGTHS STEP FORWARD TO A SUSTAINABLE FUTURE

In infrastructure projects, true performance merges efficiency with sustainability. By integrating sustainable practices, we ensure that our projects have a positive impact on the territories and populations they serve. Our approach focuses on reducing environmental impacts through optimized conception, advanced material selection, and innovative construction methods. This comprehensive lifecycle strategy combines optimization and sustainability, to meet today's needs while preserving resources for the future.



Grand Paris Express Line 15 South, FRANCE

Manage your carbon footprint with CarbonTracker

In a sustainable design approach, we developed a dedicated digital solution to carbon assessment and optimisation over the v lifecycle of an infrastructure. You can visualize carbon hotspots, manage and optimise the carbon footprint of your assets and compare different technical solutions to facilitate decision-making. Carbontracker is compatible with BIM technology (Building Information Modelling).

Optimise excavation material management with GEOMatex

Material from excavation is challenging to manage. It requires a prior assessment of the material's quality to define appropriate reuse, or in the case of polluted land, its treatment and further management. Our GIS (Geographic Information Systems) web application centralises all information relating to the management and supervision of excavated material of the project.



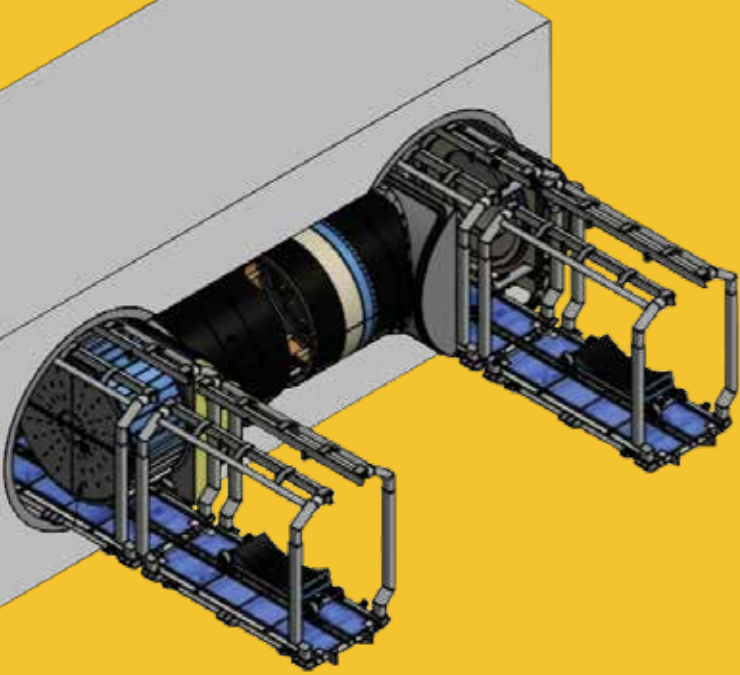

INNOVATION IN UNDERGROUND SOLUTIONS

Smart Cross Passage

Conventional cross passage excavation is characterised by many operational issues, from bringing in excavators, excavator-mounted hammer heads to drill&blast equipment. Opposed to that our innovative solution makes use of a small scale TBM, moved along the track and oriented sideways to drill through the tunnel wall. A standard segmental lining with sealing gaskets is installed during excavation, providing a complete water tightness.

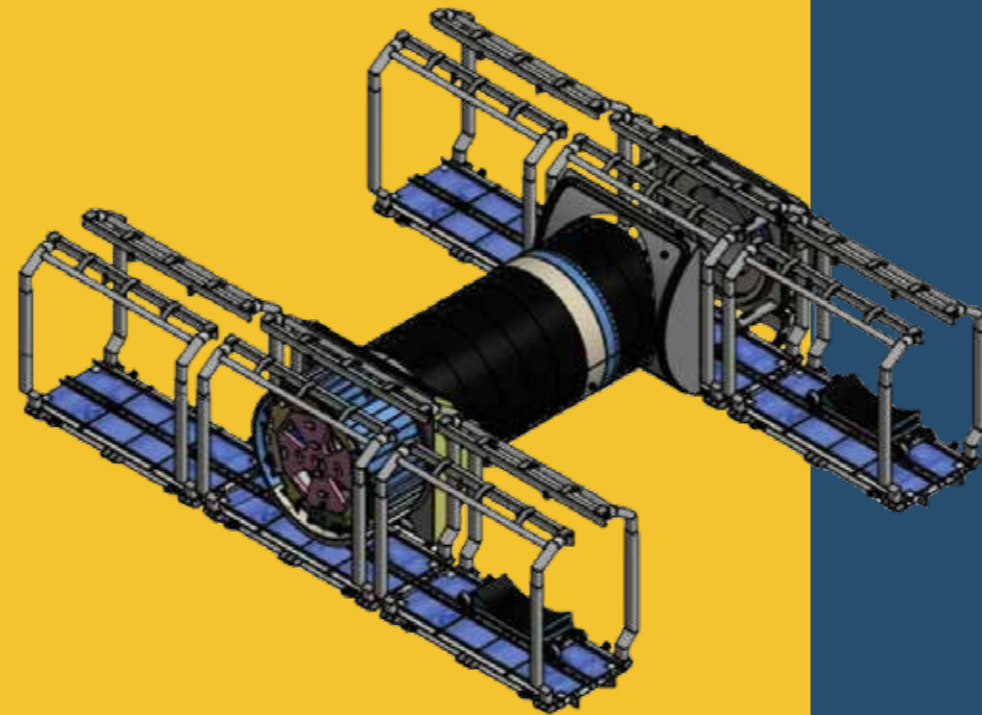

Digital model of Smart Cross Passage

Fire Safety Engineer

Considering the big benefits coming from Performance Based Design (PBD), SYSTRA provides advanced engineering services aimed at investigating the behavior of the system in terms of structural performance, Detailed analysis of the fire zone (visibility, temperature distribution, smoke...) and simulation of the evacuation process (self-rescue or assisted evacuation).

FRC Precast Lining

The implementation of steel fibres as reinforcement of concrete segments simplifies production and improves performance. We make sure to provide strong competence by constant research and collaborations in analysing FRC segments to be used, ranging from simplified equations to advanced FE models.

Expanded Soft Clay

In case of poor mechanical parameters or high coverage, a remarkable overstressing in the final lining can be expected. One countermeasure for TBM excavation can be the implementation of a compressible filling for the annular gap. To help you avoid disadvantageous solutions we propose pea-gravel to be replaced by expanded clay. The micro-structure and macro-structure of expanded clay presents a series of mechanical and technological advantages making it the ideal candidate as back-filling.

OUR SOLUTIONS ARE RELIABLE THANKS TO TECHNOLOGY-DRIVEN DESIGN AND DATA-DRIVEN ASSET MANAGEMENT

Technology-Driven Design

We systematically integrate the most advanced technologies including digital tools to assess precisely all the possible risks linked to projects and to mitigate them.

Complex facilities require powerful and centralised data management during design and construction. One of the most important results of such management is enhancing communication between the different parties working on the project. The visual models that can be built through our BIM approach provide actual proof that constructability is assured.

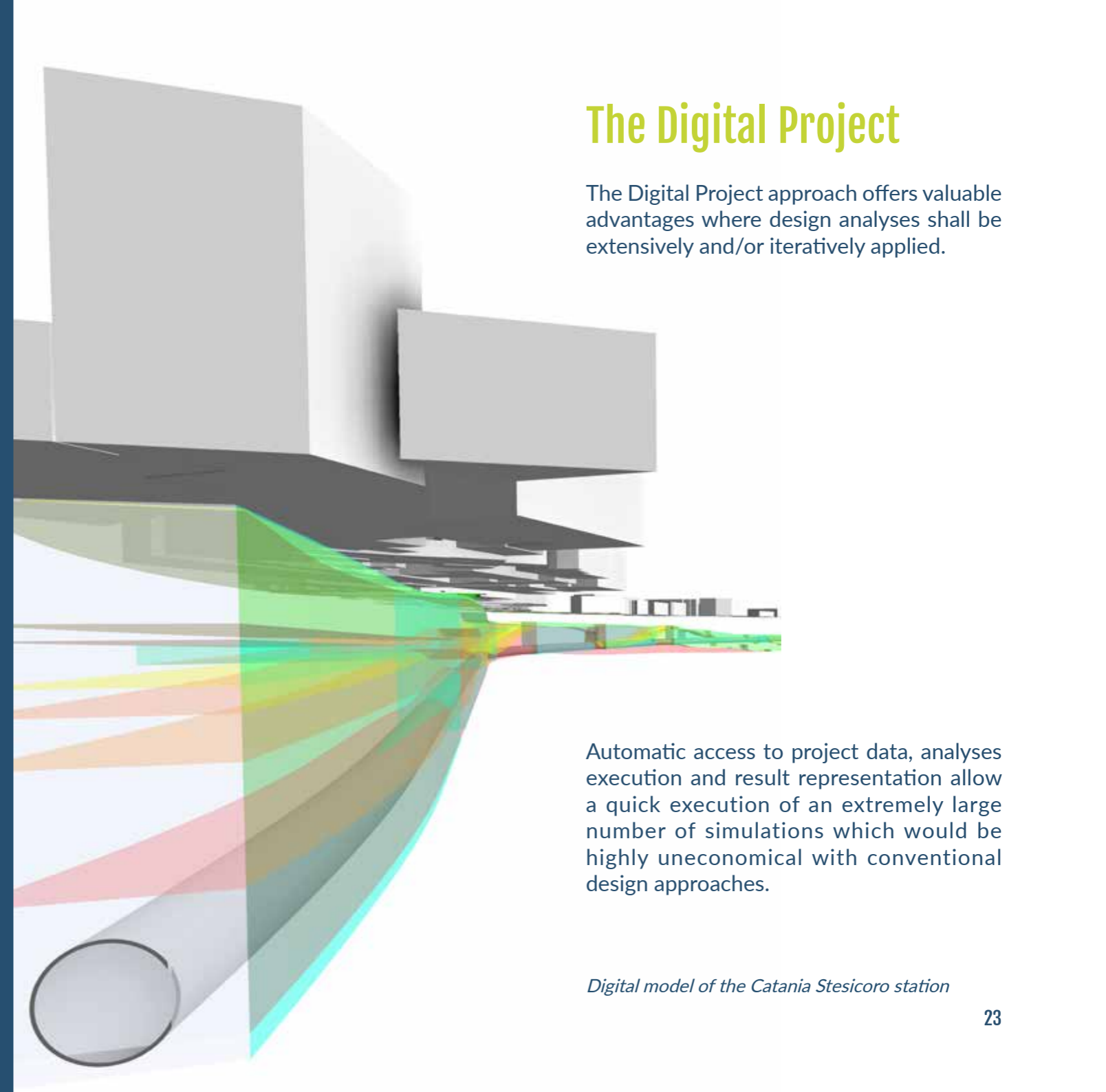

The Digital Project

The Digital Project approach offers valuable advantages where design analyses shall be extensively and/or iteratively applied.

Automatic access to project data, analyses execution and result representation allow a quick execution of an extremely large number of simulations which would be highly uneconomical with conventional design approaches.

Digital model of the Catania Stesicoro station

In-house digital solutions to create, manage and use data throughout the lifecycle

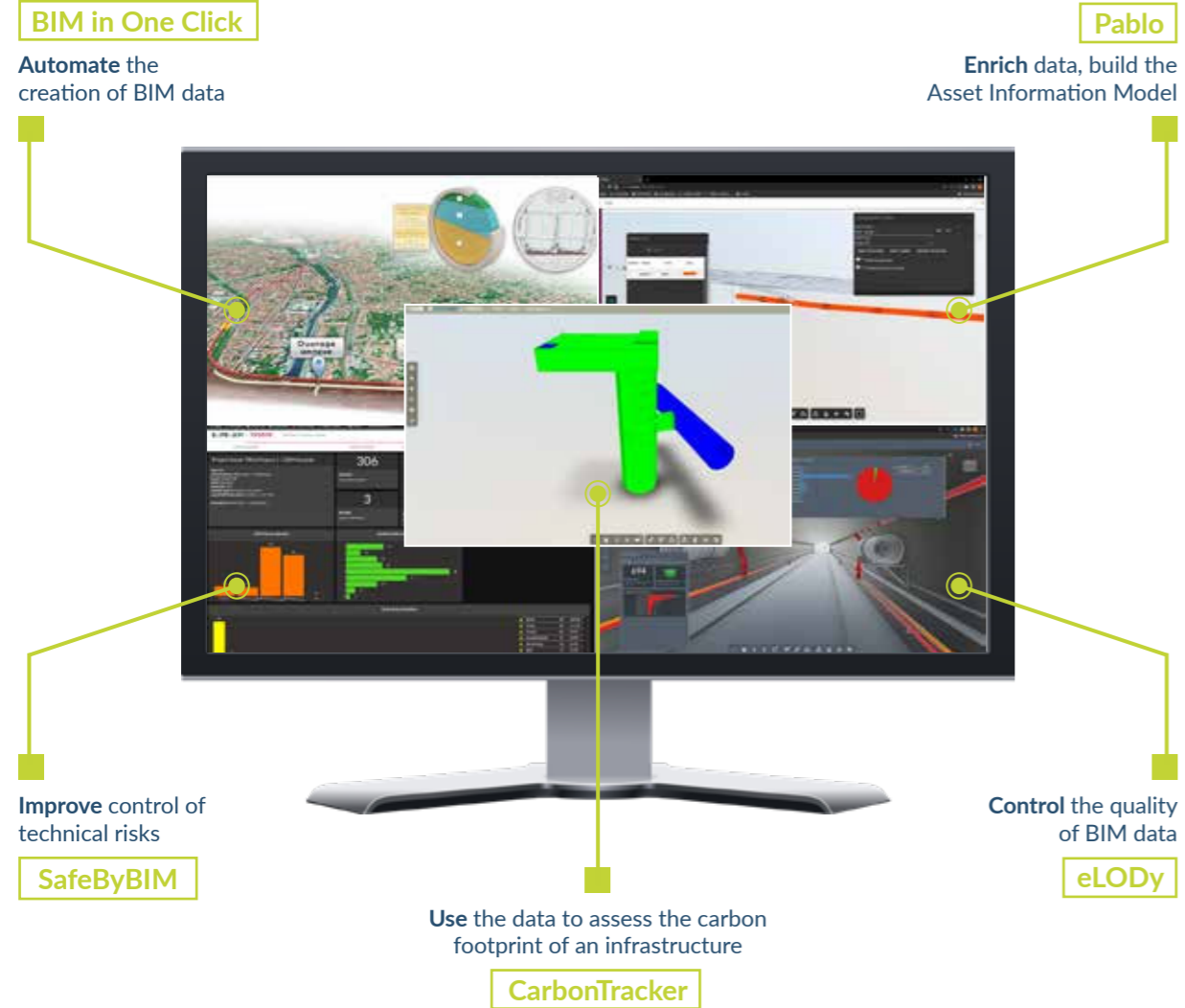

The right data at the right moment for the right person with Data-Driven Asset Management

Get to know the benefits and the value of the **DATA** provided by your systems.

Know how to **ANALYSE** & **USE** your data to optimise your maintenance.

DESIGN or **ADAPT** our systems to activate the potential of your data.

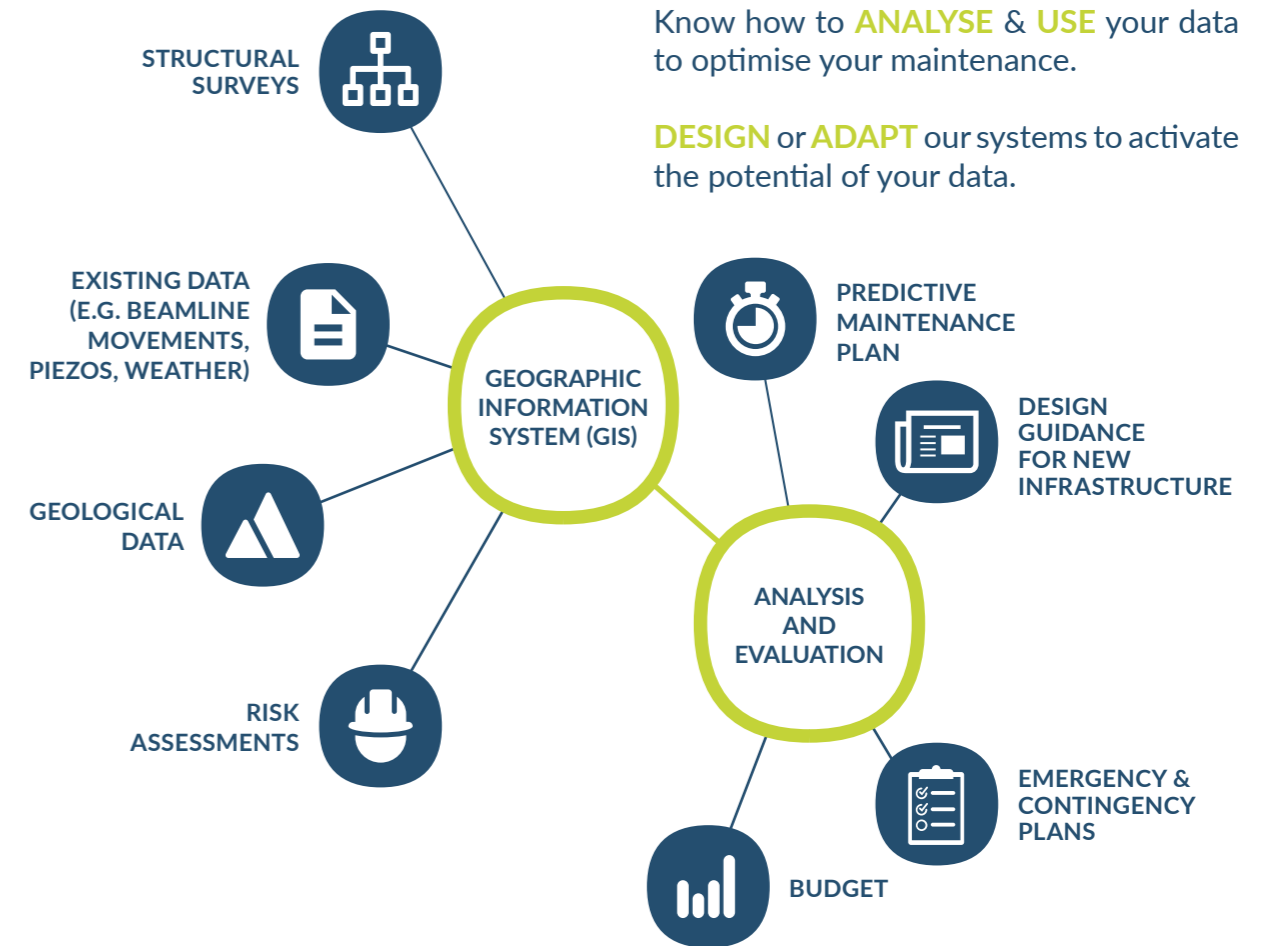

4D-Monitoring-Data Integration and real-time post-processing during Construction Phase

Excavation in soft soil, below the water table, passing under sensitive buildings and historical structures, leads to demanding monitoring requirements including real time interpretation of surveying results.

Real time interpretation comprises the definition of building and geotechnical critical parameters, the ability to correlate data coming from different sources, e.g., TBM Vs monitoring measures, and the need to compare and correlate measurements to further improve the measurement accuracy or reliability. Along with the SwissMon monitoring platform, a dedicated web platform has been

developed to fulfill data interpretation critical requirements. It allows monitoring and interpreting teams to focus on readings quality and overall project risk assessment. As a result, we avoid deploying a large amount of time and resources in data gathering and formatting, manually repeating standard procedures.

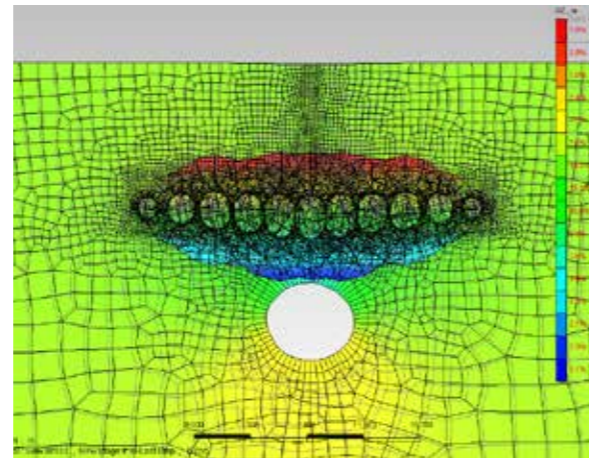
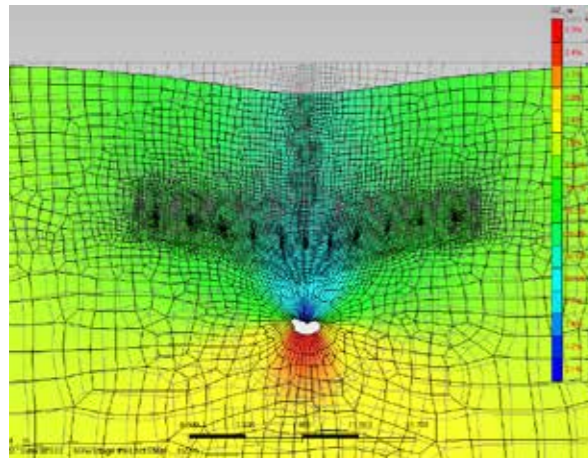

Florence HSR link, ITALY

Mitigate risk during mechanised excavation with ATAS

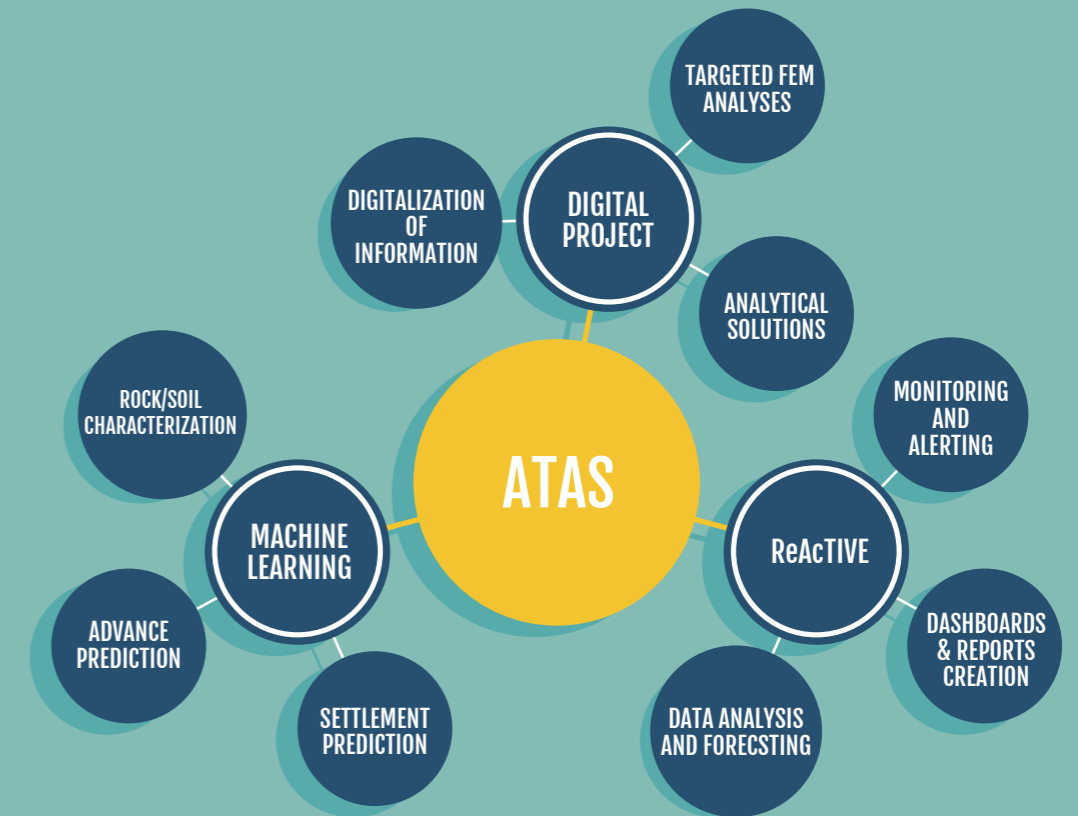

Advanced Tunnelling Assistance Systems (ATAS) is an intelligent platform that seamlessly integrates real-time data analysis, machine learning, and advanced algorithms to enhance tunnelling operations. Similar to ADAS in the automotive sector, ATAS continuously monitors excavation activities, identifies potential risks, and supports fast, informed decision-making. The development of ATAS represents years of expertise and brings together all the technologies into a cohesive, adaptive framework, a system that evolves with each excavation.



Port of Miami Tunnel, USA

YOUR PROJECTS ARE OUR SUCCESSES

OUR PROJECT PORTFOLIO

Thanks to a partner driven approach our experienced teams develop solutions for your most challenging projects around the world and deliver the best value for the entire project lifecycle. We bring together our lessons learned from an extensive portfolio of major projects worldwide.

FOLLO LINE

Reducing environmental impact and avoiding traffic disruption during construction

2015 - 2021

The Follo Line project is a new railway line between Oslo Central Station and the public transport hub at new Ski station (20km long twin tunnels). The concrete tunnel will be connected to both existing constructions at Oslo Central station and to the long tunnel, the longest railway tunnel to date in the Nordic countries.

The Drill & Blast contract includes the construction of several tunnels built in Ekebergåsen (1.3km), a hill formed by gneiss of the Precambrian period with presence of alum shale, located east of the Oslo fjord. The tunnel (design and construction) has a lot of challenges due to the presence of existing tunnels (raw water tunnel and escape tunnels) and oil deposits (watertight section).

The Oslo S contract includes the construction of a Cut and Cover tunnel (up to 6 tubes, 625m long) and 4 technical buildings. The cut and cover area is characterised with severe geotechnical conditions - quick clay - that required the use of ground improvement (jet grouting).

CONSTRUCTION:
Completed in 2021



OWNER/CLIENT:
Bane NOR

PROJECT VALUE:
Drill & Blast: €150mln
Oslo S: €200mln

- OUR ROLE:**
- BIM Modelling
 - Detailed Design
 - Assistance and Technical Services during construction
 - As built drawings



Rail



PORT OF MIAMI TUNNEL

Very complex ground conditions including an excavation in soft rock

2009 - 2013

POMT is an underwater 1,260km long road tunnel bored under the main navigation channel of the Biscayne Bay. SYSTRA provided Technical Assistance to the Concessionaire in Design and Construction phases.

The main challenge of this project was the construction of the twin-tube tunnel (around 13m diameter) in difficult soil conditions - a coral massif with high permeability and high variability and soft rock - a very unusual and technically difficult context. Moreover, the maximal depth was 36.58m with the water pressure reaching up to 3.5 bars. For those reasons specific solutions were provided, including ground improvement techniques and ground freezing - for the first time in Miami limestone along with TBM hybrid tunnel boring machine that works in earth pressure mode or in hydraulic mode.



OWNER:
Florida Department of Transport

CONTRACTOR:
Bouygues TP

CLIENT:
Miami Access Tunnel Concessionaire

PROJECT VALUE:
€800mln

OUR ROLE:

- Technical Expert
- Assessor
- Advisor

CONSTRUCTION:
Completed in 2014



Road



BRENNER BASE TUNNEL, LOT MULES 2-3

A technological world first in a record cross border tunnel between Innsbruck and Fortezza

2016 - 2019

BBT is an extremely complex tunnel system. Besides the two main tubes and the exploratory tunnel, there are many connecting branches, side elements and emergency stops plus four lateral access tunnels. BBT main tubes run for about 64km (55km Brenner Base Tunnel and 9km Innsbruck bypass), making it one of the longest underground railway stretches in the world. This exceptional infrastructure represents a true engineering challenge because of its intrinsic geometrical complexity and the extreme variability of encountered rock masses. We supported the client during the selection process of the most effective TBM - the reliability of this choice guaranteed by our Digital Project Hard Rock tool to perform a statistical evaluation of the problem (based on Monte Carlo algorithm).

The design need for a collapsible backfilling brought SYSTRA to review the state of the art. Expanded clay was identified as the most promising solution. Mechanical characterisation and its applicability were not well developed at that time and SYSTRA set up a research project to provide the best possible solution to our clients' needs.

CONSTRUCTION:
Expected completion in 2029



OWNER:
BBT SE

CONTRACTOR/CLIENT:
BTC Brennero Tunnel Construction

PROJECT VALUE:
€993mln

- OUR ROLE:**
- Detailed Design
 - BIM Design
 - TBM Selection
 - MEP Design
 - Technical Assistance during construction

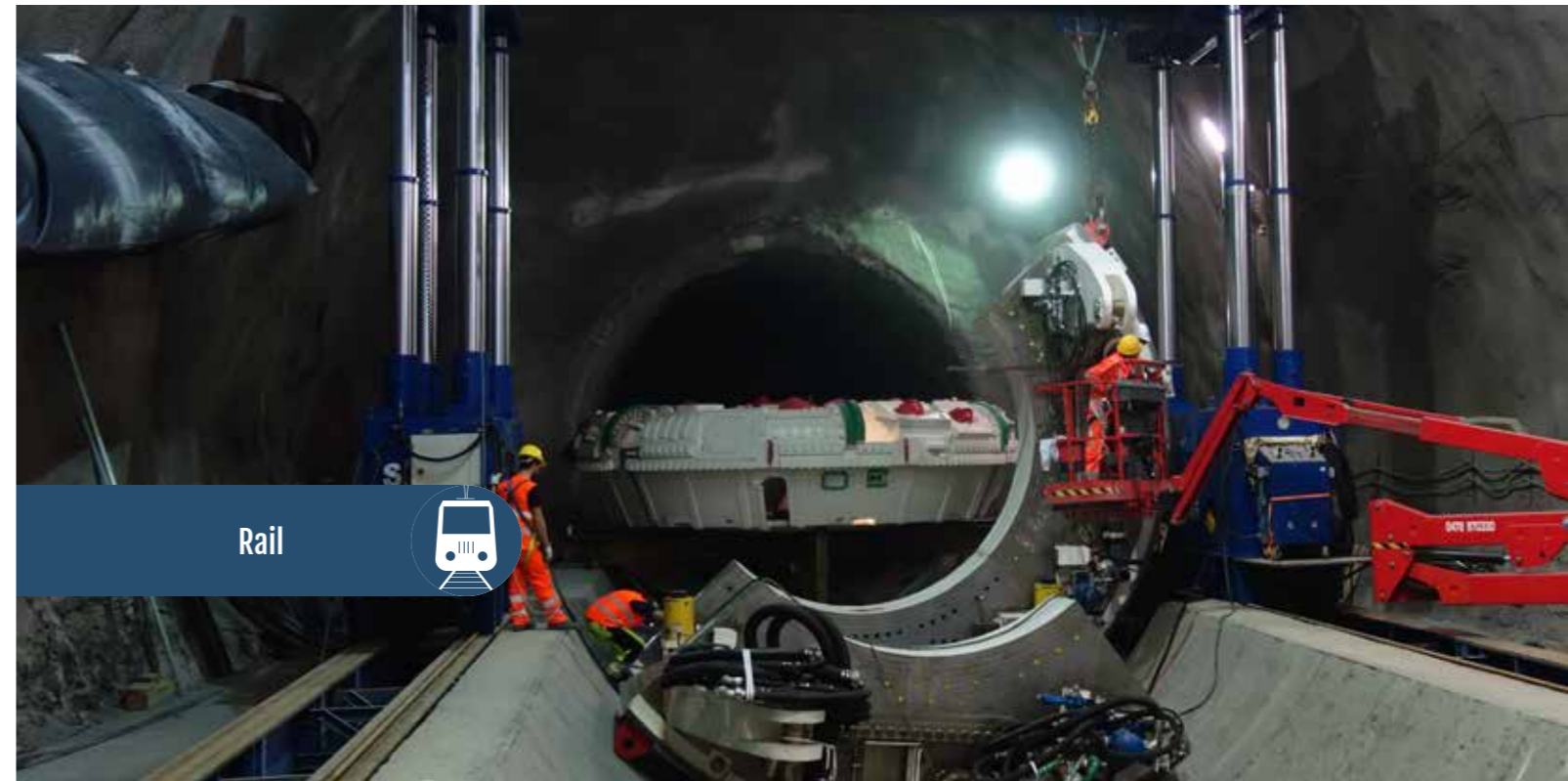

Rail



HANOI PILOT LIGHT METRO LINE

FIDIC standards implemented for contracts

2007 - Ongoing

SYSTRA was involved at many stages of the modernisation of this complex project consisting in a total length of 12.5km including 8.5km of elevated section and 4km of underground section with twin tunnels and 4 stations built by cut and cover method.

The main challenge encountered was meeting the huge transportation demand in the very crowded urban space and for that reason, a specific construction method for TBM tunnelling under piles found buildings was implemented. Mitigation works were proceeded for the connection to the shaft along with counter-measures in case of excessive settlement during excavation.



OWNER:
Hanoi People's Committee

CONTRACTOR:
Hyundai E&C and Ghella JV

CLIENT:
Hanoi Metropolitan Railway Management Board (MRB)

PROJECT VALUE:
€1,176mln

OUR ROLE:
▪ Project Implementation Consultant



CONSTRUCTION:
Expected completion in 2027



MONT CENIS BASE TUNNEL TUNNEL EUROALPIN LYON-TURIN (TELT)

The longest structure of this kind worldwide

2018 - Ongoing

The Lyon-Turin HSR Project is a key part of the Mediterranean Corridor of The Trans-European Transport Network (TEN-T) - a European global project on the development of a cross-border rail network to link Europe from east to west. The cross-border stretch of 65km, includes a bi-national tunnel 57.5km long Mont Cenis base tunnel (12.5km in Italy and 45 in France) linking the international stations of Saint-Jean-de-Maurienne and Susa, which constitute the connection points to the respective national lines in France and Italy. Once completed it will considerably shorten the journey times from the nearly 4 hours to less than 2 hours between Lyon and Turin. It is estimated that nearly 4.5 million passengers will use the planned route every year, providing significant environmental benefits to the surrounding region.

The construction of twin tunnels under the Alps is challenging because of particularly complex geological conditions and high overburden reaching 1,800m. For that reason, Drill & Blast, Shield TBMs and Gripper TBMs are designed as construction methods.

CONSTRUCTION:
Expected completion in 2030



OWNER/CLIENT:
Tunnel Euroalpin Lyon-Turin (TELT)

CONTRACTOR:
CO1, CO2, CO3/4: under assignment
CO7: Vinci Grand Construction Project,
Dodin Campenon Bernard, Vinci
Construction France and Webuild JV
CO8: Implenia, NGE, Itinera and Rizzani
de Eccher JV

PROJECT VALUE:
€8,600mln

OUR ROLE:

- General Consultant
- Project Manager
- Project Management Consultant
- Detailed Design



CHEVES HYDROELECTRIC POWER PLANT

High stress conditions in the deep sections of the underground structures causing severe rock bursts

2010 - 2014

The Cheves hydroelectric power plant is located in the central highlands of Peru, department of Lima. The project includes two concrete dams (Huaura and Checras rivers at 2,170masl) upstream of the headrace tunnel, interconnected through a transfer tunnel 2,580m long, and a third dam (Picunche dam at 1,548masl).

SYSTRA was responsible for the detailed design of the underground structures and the technical assistance during construction including around 20km of tunnels (transfer, headrace, surge, access, and tailrace), powerhouse complex with 2 caverns.

Several challenges were encountered such as thermal waters, squeezing, and especially 864 rock bursts. The design performed by SYSTRA include a risk assessment process and all the mitigations measures adopted.



PERU

OWNER:
STATKRAFT PERU

CLIENT/CONTRACTOR:
CHT JV (HOCHTIEF - TECSA)

PROJECT VALUE:
€456.7mln

OUR ROLE:

- Detailed Design
- Technical Assistance during construction

CONSTRUCTION:
Completed in 2014



Hydroelectric



SYDNEY METRO

The biggest public transport project in Australia

2011 - Ongoing

Sydney Metro is Australia's biggest public transport project. By 2030, Sydney will have a network of 4 metro lines, 46 stations and 113km of new metro rail.

The SYSTRA team have been instrumental across all four active Sydney Metro projects across the project lifecycle. On Sydney Metro Northwest the team were part of the integrated team developing the tunnelling constructability solution for the project. During the Sydney Metro City and Southwest, the team led complex concrete lining operations, including the formwork design and construction methods development.

On SMWSA SYSTRA developed the TBM strategy including machine selection for the project in Bringelly Shale. As part of the SMW project the team have been instrumental delivering design and construction outcomes, leading the technical solution through concept design, transaction and into delivery for Sydney Metro.

CONSTRUCTION:
Expected completion in 2032



OWNER/CLIENT:
Sydney Metro and Transport for New South Wales

PROJECT VALUE:
€36.20bln

- OUR ROLE:**
- Technical Tunnel Advisor
 - Business Case Constructability Advisor
 - Delivery Support
 - Specialist Tunnel Constructability Services



MECHANISED



CONVENTIONAL



CUT AND COVER

CONTRACTOR:
WEST: Acciona Ferrovial JV Gamuda, John Holland CPB Ghella JV
WESTERN SYDNEY AIRPORT: CPB Ghella JV
CITY AND SOUTHWEST: John Holland CPB Ghella JV
NORTHWEST: John Holland Thiess Dragados JV



ANTAMINA MINE

One of the largest mining investments in the history of Peru

2017 - 2023

The Antamina mine, one of the largest copper and zinc mines in the world, is located in the Andes Mountains of Peru at an average altitude of 4,300 metres above sea level. This open pit mining project is one of the largest mining investments in the history of Peru (around 3.6 billion dollars) which includes the investment in the expansion of its operations.

Since 2017 SYSTRA has participated in 3 main underground contracts such as supervision of the rehabilitation of the current transportation tunnel that connects the primary crusher and the plant (2,600m) and the design of new tunnel transportation infrastructures (2 tunnels of total length of 7,200m). More recently SYSTRA has provided supervision services (including lab tests, quality control and H&S) for the excavation, support, civil works and grouting during the construction of the Side Hill and Decantation tunnels located in the tailings dam (the total tunnel of 1.5km).



PERU

OWNER:

Cia Minera ANTAMINA

CLIENT:

Contract 1 & 3: Cia Minera ANTAMINA
Contract 2: DRA Ingenieria

CONTRACTOR:

Contract 1: Maccaferri
Contract 3: JME JV (JJC and Mas Errezuriz)

PROJECT VALUE:

€2bln

OUR ROLE:

- Site supervision
- Technical Assistance during construction
- Detailed Design



CONVENTIONAL

CONSTRUCTION:
Completed in 2023

WESTCONNEX

The largest integrated transport and urban revitalisation project in Australia

2015 - 2023

WestConnex is a 33km road project, comprising more than 19km of twin tunnels, aimed at easing traffic congestion and connecting Sydney's port and airport precincts. Due to its size, the scheme has been divided into 3 stages and 5 major contracts. The project was excavated by 86 road headers.

SYSTRA provided specialist tunnel engineering services to the client-side team across the entire programme of works. This support included Tunnelling Construction Directors, M&E Construction Directors, and Commissioning Directors alongside a significant team of underground professionals who provided an integrated project delivery service as part of the client delivery team.



AUSTRALIA

OWNER/CLIENT:

Transport for New South Wales (TfNSW)
TransUrban

CONTRACTOR:

Stage 1B: CPB Contractors, John Holland, Samsung JV
Stage 2: CPB Contractors Dragados Samsung JV
Stage 3A: Acciona, Samsung Bouygues JV
Stage 3B: John Holland CPB Contractors

PROJECT VALUE:

€10.29bln

OUR ROLE:

- Procurement Support
- Constructability Support
- Integrated Project Delivery Support
- Transaction Phase Advice



CONVENTIONAL

CONSTRUCTION:
Completed in 2023

Mining



Road



HAGA WEST LINK, GOTHENBURG

Minimising surface settlements by maintaining the natural groundwater lever during construction

2019 - Ongoing

The E04 Haga project is part of the West Link, a railway tunnel running underneath central Gothenburg, requiring the construction of three new stations and connecting commuters with transit traffic. The E04 Haga contract includes a rock tunnel and a station to be mostly excavated in clay. In more detail, the E04 Haga contract will be connected with the E03 Kvarnberget project on the northern side and with the E05 project on the south. The project will increase the city capacity for environmentally friendly transport, and will reduce travel time.

Complicated structure in urban areas (clay part: cut and cover, rock part: cavern). Challenging geotechnical conditions (excavation is carried out partially in sound rock and mostly in clay). Challenging hydro conditions (lower and upper aquifer to be properly sealed during the excavation to avoid lowering of water table and, as a consequence, minimise settlements at ground surface and in surroundings. Part of the station to be constructed under an existing building (Skattehuset) to be preserved. Huge interference with natural constraints, such as excavation under Rosenlund Canal.

CONSTRUCTION:
Expected completion in 2028



OWNER:
Trafikverket (Swedish Transport Administration)

CONTRACTOR/CLIENT:
AGN Haga (Astaldi, Gülermak and NRC Group Joint Venture)

PROJECT VALUE:
€222mln

- OUR ROLE:**
- Value Engineering
 - BIM Modelling
 - Detailed Design
 - Construction Management

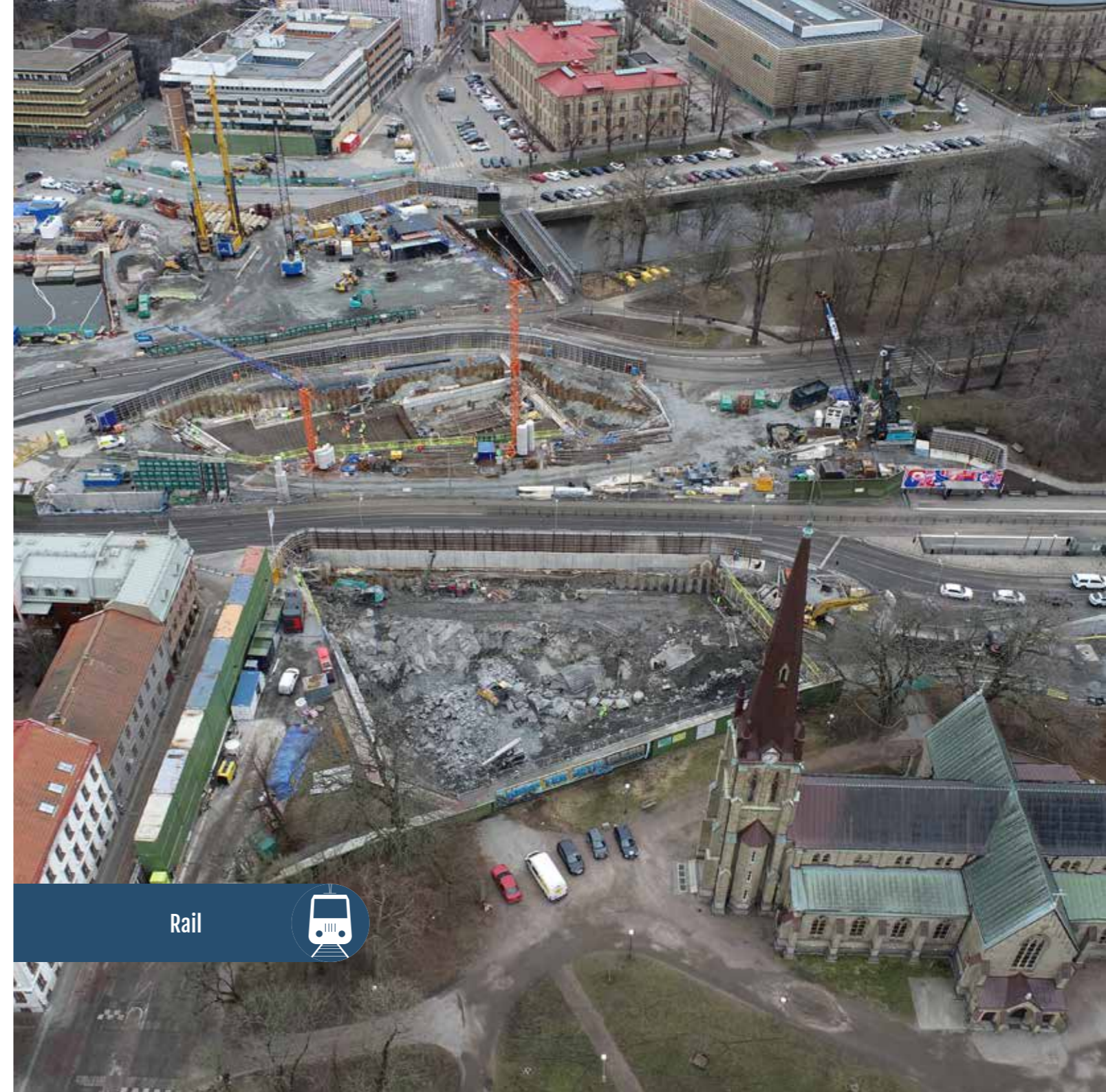

MUMBAI METRO LINE 3

Excavation in difficult ground conditions including hard rock and in a very congested urban environment

2016 - Ongoing

The project is the first underground metro line in Mumbai. The Aqua Line 3 of the Mumbai Metro, also known as Colaba-Bandra-Seepz Line, is a part of the metro system under construction in Mumbai, India. When completed, the 33.5km long line will be the first underground metro line in Mumbai and will be operated by MMRC. The metro line will connect Cuffe Parade business district in the extreme south of the city to SEEPZ in the north-central with 26 underground and 1 at-grade station.

SYSTRA was involved in the detailed design in Package UGC-01. UGC-01 is one of the 7 packages being awarded for full Mumbai Metro Line-3 which extends from Colaba to Seepz area. This package covers 4 stations namely Cuffe Parade, Vidhan Bhavan, Churchgate and Hutatma Chowk and associated tunnels. Three stations are purely cut and cover stations and Hutatma Chowk has one tunnel to be constructed using NATM techniques. Underground construction was carried out at an average depth of 15 to 25 meters. Total 4 TBMs were deployed for tunnelling activity.

CONSTRUCTION:
Expected completion in 2026



OWNER/CLIENT:
Mumbai Metro Rail Corporation Limited (MMRCL)

CONTRACTOR:
Larsen & Toubro and Shanghai Tunnel Engineering Co.

PROJECT VALUE:
€2,740mln

OUR ROLE:

- Detailed Design Service
- Designers support during construction



GRAND PARIS EXPRESS LINE 15 SOUTH

Deep excavation and ground freezing techniques implemented

2015 - Ongoing

The L15 south package T2 line project includes the construction of a 21km tunnel, 8 stations and 19 shafts, in very dense urban areas and crossings under the Seine and Marne rivers. Located to south-east of Paris, Package T2A includes the construction of four stations, several related structures, 7.7km of tunnels, and the launch shaft for the TBM.

One particularity here is that the soil is varied and complex, thus calling for very special techniques to reinforce it. The Vert de Maisons station is built with 74-m-deep diaphragm walls and using conventional methods for the foundation excavation, the Vert de Maisons station requires ground freezing and injection techniques to stabilise the soil. Moreover, the tunnelling proceeded under the Parisian suburbs to be transformed into the future greatest metropolis in Europe.

CONSTRUCTION:
Expected completion in 2026



OWNER/CLIENT:
Société du Grand Paris

CONTRACTOR:
T2A: Horizon (Bouygues and Soletanche Joint Venture)
T2B: Eiffage GC and Razel-Bec JV
T2C: Alliance
T2D: Vinci and Spie Batignolles
T2E: Léon Grosse and Dacquín JV

PROJECT VALUE:
€ - confidential

OUR ROLE:

- Infrastructure Design
- Construction Management Contracts
- Detailed Design

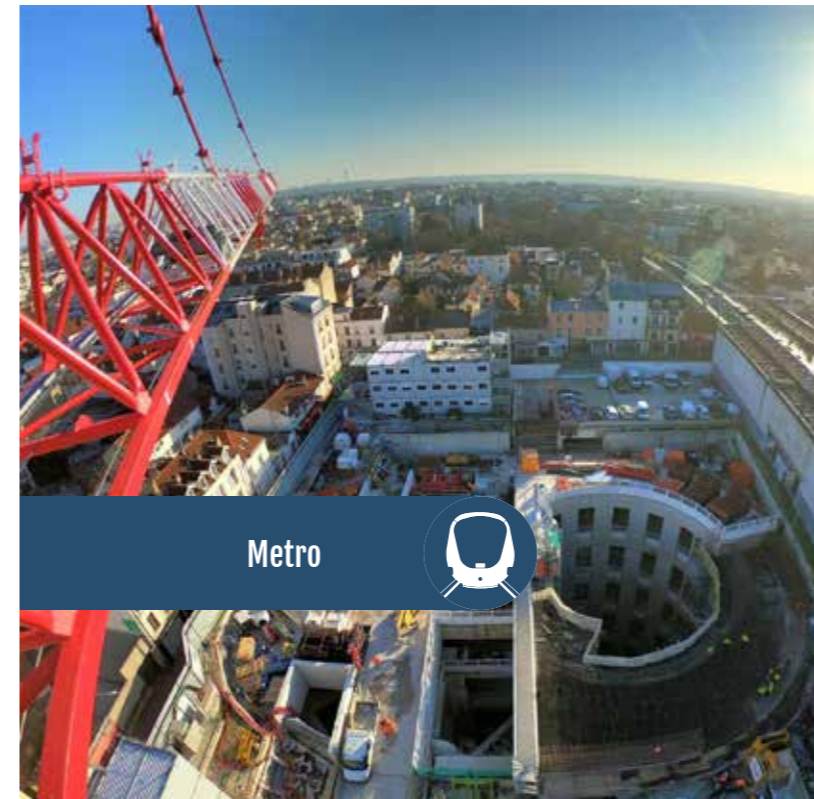

VESTFOLD LINE, NYKIRKE - BARKÅKER

Difficult groundwater conditions and rock excavation

2019 - 2026

The project consists of a new double-track railway (13.6km) with a train station adjacent to the urban area of Skoppum. It includes rock tunnels, 1 cut and cover concrete tunnel, 17km of roads (permanent and temporary), 3 bridges and 1 train station.

The entire area of the project is constituted mainly of clay and the new alignment has been designed for a maximum speed of 250km/h and will reduce the journey time between Drammen and Eidanger. Tunnels are excavated mainly in hard rock and with Drill & Blast. Rock support and water frost protection is designed in accordance with local technical requirements. Plain concrete is implemented all along the tunnel and in crossing and niche sections reinforcement lining is used.



OWNER:
Bane NOR

CONTRACTOR/CLIENT:
SAPINOR (Webuild and Impresa Pizzarotti & C. Joint Venture)

PROJECT VALUE:
€370mln

OUR ROLE:

- Value Engineering
- BIM Modelling
- Detailed Design
- Construction Management



CONSTRUCTION:
Completed in 2026



WEST GATE TUNNEL

Highly variable geological conditions and presence of contaminated soils

2021 - 2025

The West Gate Tunnel project will remove Melbourne's reliance on the West Gate Bridge and provide new links to the Port, CityLink and CBD. The scope includes the construction of twin 3 lane tunnels, a second crossing of the Maribyrnong River, upgrades to the West Gate Freeway and a new cycling connection.

The presence of perceived contaminated soil from past industrial use in the project area brought many activities including tunnelling to a halt in late 2019 until a solution for waste disposal could be reached. Tunnelling did not start again until early 2022. The geological conditions were highly variable, requiring a closed face EPB TBM. Tunnel excavation on both drives was completed by May 2023.

SYSTRA are providing tunnel design and construction delivery support as part of the integrated client team delivering the project.

CONSTRUCTION:
Completed in 2025



OWNER/CLIENT:
TransUrban

CONTRACTOR:
CPB Contractors John Holland JV

PROJECT VALUE:
€6.12bln

OUR ROLE:
▪ Project Delivery Support

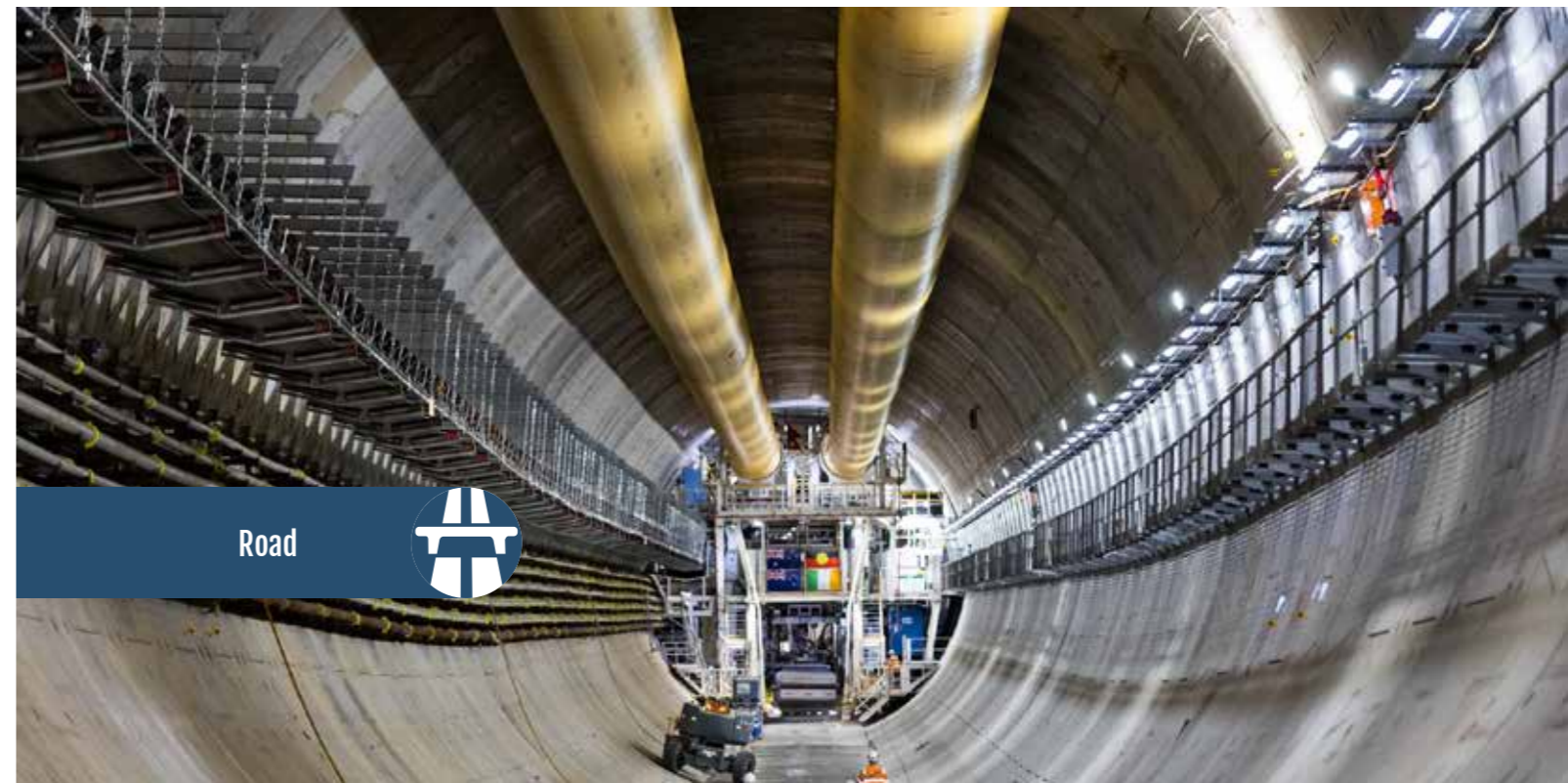

Road



PAVONCELLI BIS HYDRAULIC TUNNEL

The backbone of an entire region's water system

2013 - 2019

The project consists of an 8km tunnel excavated using a 4.57m diameter EPB TBM, two adits, a connecting tunnel excavated with conventional method and a shaft. The alignment includes existing sections, flooded or damaged sections, new excavations, and different geologies. This has required a complex design and preparation of the boring machine to overcome any possible difficulties during the excavation as well as its complex geological alignment. Severe geological conditions with a high risk of flammable gases were managed.

The rings for the internal lining have been placed in all sections, so as to obtain the same dimension throughout the entire alignment and guarantee a correct flow of water throughout its length.



OWNER:
Ministero delle Infrastrutture
e dei Trasporti

CONTRACTOR/CLIENT:
Vianini Lavori

PROJECT VALUE:
€115mln

OUR ROLE:

- Detailed Design
- Monitoring Follow up
- Technical Assistance during construction



CONSTRUCTION:
Completed in 2019

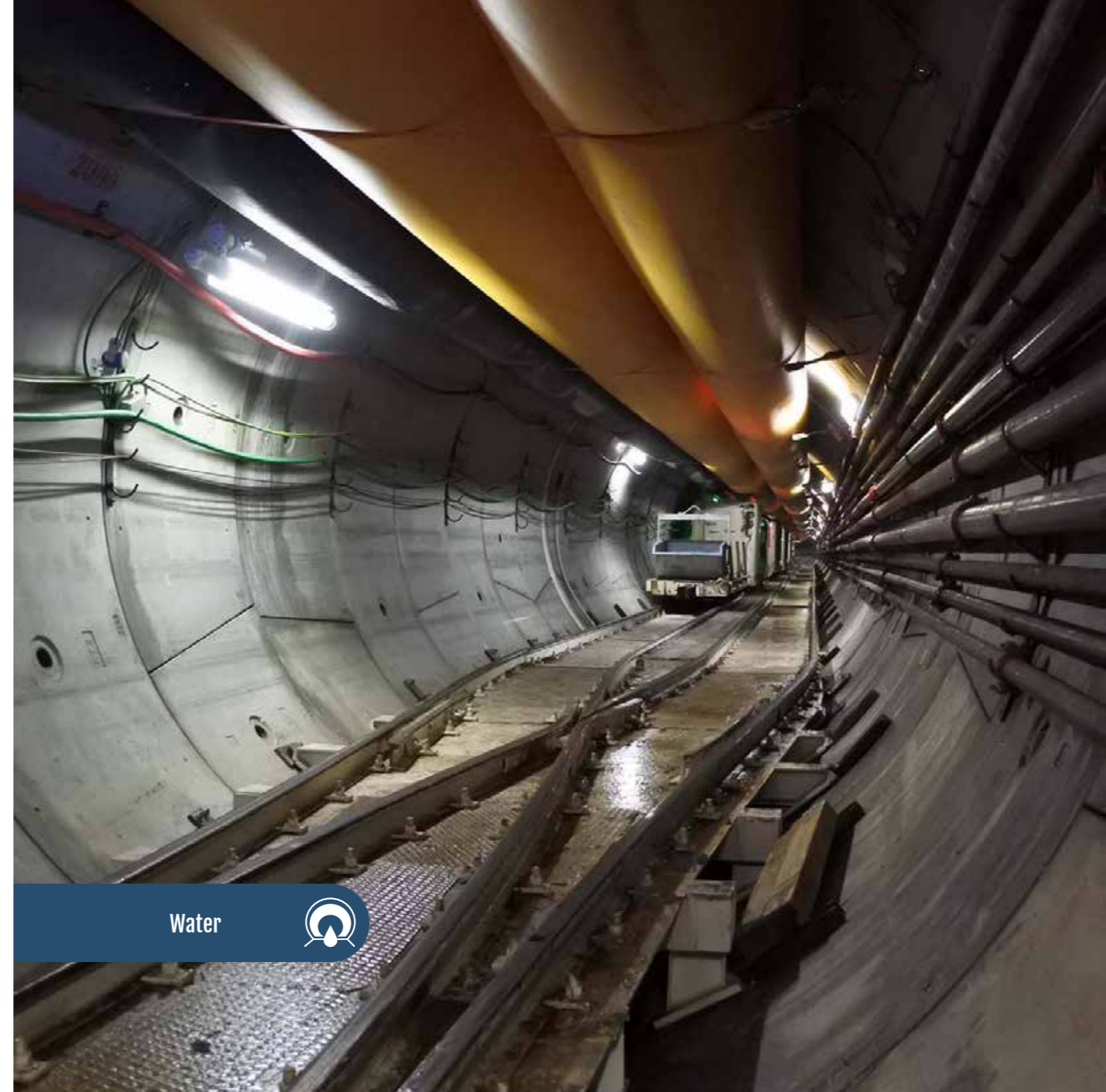

Water



PORT SAID ROAD TUNNEL

Boring in complex ground with high water-pressure

2015 - 2018

The Port Said Tunnels Project comprises twin-tube, dual-carriageway road tunnels. The two, 2.85km tubes reach a maximum depth of 57m below ground level with a minimum clearance of 18m below the bottom of the strategically important Suez Canal waterway.

The project met challenges of a very tight design and construction schedule, with excavation in poor and mixed soil conditions containing methane gas, and with groundwater pressures reaching high values up to 6 bar. Cross passages were constructed using ground freezing techniques.



EGYPT

OWNER:

The Ministry of Defence of the Government of the Arab Republic of Egypt

CONTRACTOR:

Arab Contractors and Orascom JV

CLIENT:

Engineering Authority of the Egyptian Armed Forces

PROJECT VALUE:

€800mln

OUR ROLE:

- Employer's Representative
- General Consultant



MECHANISED



CUT AND COVER

CONSTRUCTION:

Completed in 2019



Road



LYON METRO LINE B EXTENSION

99.9% of excavated material recovered

2015 - 2025

The extension of line B of the Lyon metro consists of a 2.5km extension towards the Lyon South Hospitals. The main challenges on this project concern the excavation of highly permeable soils including boulders under old sensitive buildings and very heterogeneous geology ranging from clays to coarse glacial tills (boulders) and hard rock (basement).

The tunnel boring project is a shining example of our sustainable development vision, thanks to the recycling of excavated materials which was implemented by SYSTRA: 150,000 tonnes of the 400,000 tonnes excavated by the TBM were reused on site, thanks to the recycling of sand in the tamping mortar and the recharging of the tunnel with untreated gravel, saving the traffic of more than 7,000 lorries and the use of surplus materials, equivalent to 300t CO2.

CONSTRUCTION:
Completed in 2023



OWNER/CLIENT:
Syndicat Mixte des Transports pour le Rhône et Agglomération Lyonnaise (SYTRAL)

CONTRACTOR:
GC01: Implenia & Demathieu Bard
GC02: NGE
GC03: Maïa Sonnier

PROJECT VALUE:
€ - confidential

OUR ROLE:

- Update of feasibility studies
- Preliminary and Detailed Design
- Assistance in preparation of tender
- Site Supervision of the civil works and rail installation

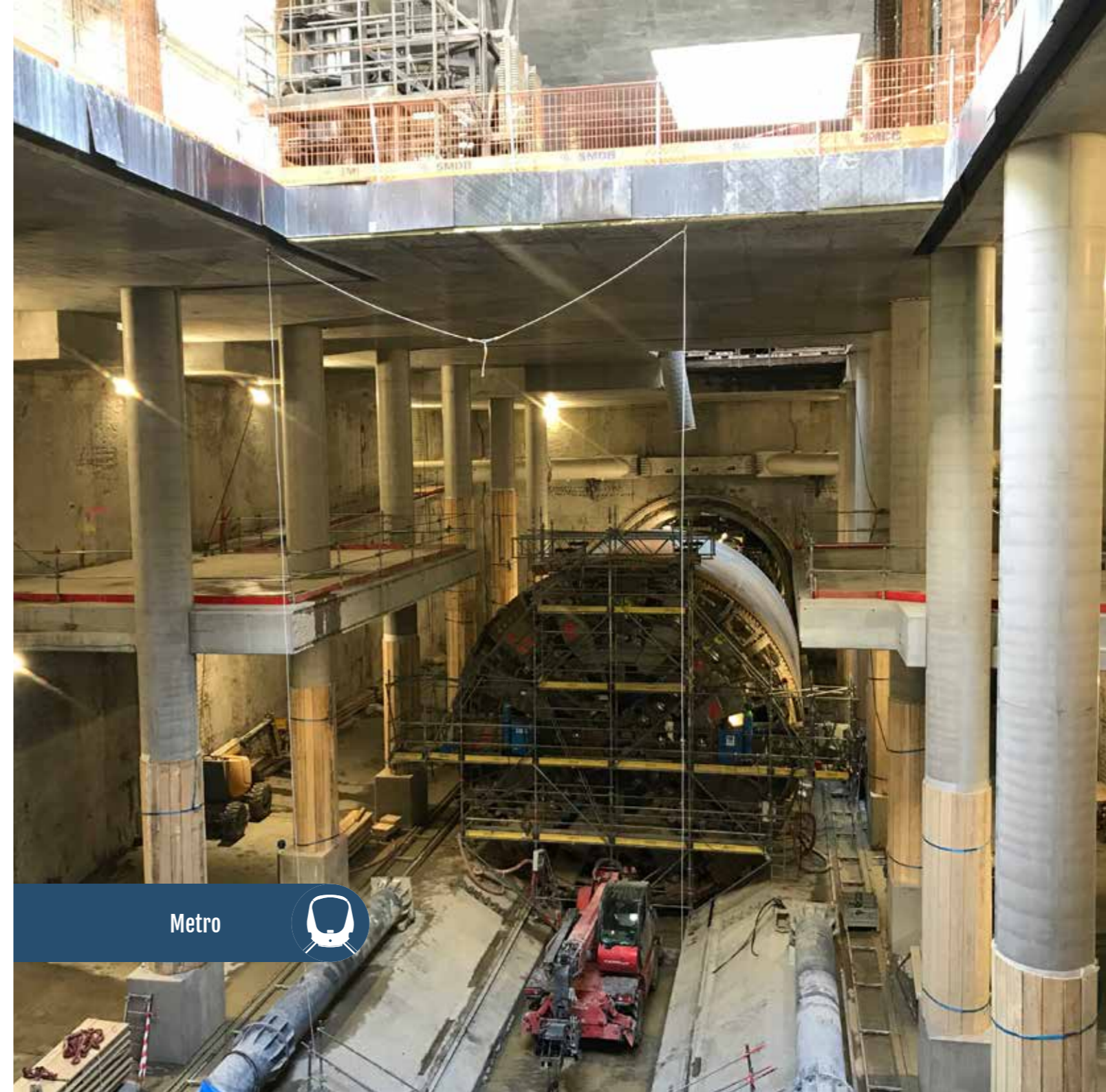

Metro



A14 BOLOGNA-BARI-TARANTO HIGHWAY

Widening of one of the main Italian highways with no traffic disruption

2012 - 2017

The goal of the intervention is to widen to the third lane the A14 Bologna-Bari-Taranto highway between Ancona north and Ancona south, for a total length of 17km including the Sappanico and Montedomini highway tunnels.

The main challenge of the project is to keep the highway in operation with the minimum disruption during construction. Innovative methods have been developed to allow efficient tunnel construction while ensuring the safest environment for workers and public.



OWNER:
Autostrade per l'Italia

CONTRACTOR/CLIENT:
Ghella

PROJECT VALUE:
€296mln

OUR ROLE:

- Preliminary Design
- Detailed Design
- Technical Assistance during construction



CONSTRUCTION:
Completed in 2017



Road



ROAD CONTOUR OF CARAGUATATUBA & SÃO SEBASTIÃO

Special excavation work in meta gabbro rock

2013 – 2016

Rodovia dos Tamoios (SP-099) is the main link between the Metropolitan region of São Paulo city and the North Coast of the State of São Paulo. It is a single lane road with increasing congestion, especially due to seasonal tourist traffic during summer, holidays and weekends. The expansion of the 104km long road, called Nova Tamoios, had the main benefits of reducing travel time and fuel economy, as well as increasing safety conditions for all users.

One of the main concerns was the location of the tunnel in an area where the hydrographical conditions are susceptible to debris flow events.



BRAZIL

OWNER:

Sao Paulo State Government

CONTRACTOR/CLIENT:

Desenvolvimento Rodoviário S.A. (DERSA)

PROJECT VALUE:

€250mln

OUR ROLE:

- Technical Expert
- Assessor
- Advisor General Consultant
- Project Manager
- Design Engineering

Road



CONSTRUCTION:

North Contour completed in 2023
South Contour completed in 2024



CONVENTIONAL

ŁÓDŹ CROSS-CITY LINE

A tunnel excavated in a very urbanised city context

2019 – Ongoing

An efficient and environmentally friendly underground transport system to boost the local economy, trade, and tourism. The railway infrastructure will connect three major railway stations: Łódź Fabryczna - Łódź Kaliska - Łódź Żabieniec. The project includes the construction of two stations, Łódź Zielona and Łódź Ogrodowa.

Two EPB TBMs, 8.8m and 13m dia. excavate a tunnel under the dense urban environment of the city of Łódź in Poland, crossing historic buildings in the city centre with limited overburden. The alignment involves multiple break-in and break-out locations as well as complex TBM assembly and dismantling operations.



POLAND

OWNER:

PKP Polskie Linie Kolejowe S.A.

CONTRACTOR/CLIENT:

Przedsiębiorstwo Budowy Dróg i Mostów (PBDiM)

PROJECT VALUE:

€307mln

OUR ROLE:

- Tunnel Design
- MEP Design for tunnel and stations
- Fire and Life Safety
- Construction Management

Rail



CONSTRUCTION:

Ongoing



MECHANISED

AMÉRICO VESPUCIO ORIENTE (AVO 1)

Large tunnel section under a highly congested urban area mainly in alluvial gravels

2014 - 2022

The 'Américo Vespucio Oriente Concession, Section Av. El Salto-Príncipe de Gales' (AVO 1) is part of an ambitious public-private partnership programme, promoted by the Chilean Ministry of Public Works.

The project addresses the challenge of integrating into an urban space an 8.3-km highway with three lanes in each direction, of which 7.7km are underground. The underground works combine different construction methods including NATM for a 2.5-km section (La Pirámide and Mapocho Branch Tunnels, a bifurcation cavern of 29.5m width and two shafts) and a Cut & Cover for 2.9km in a pile trench with two subway platform levels and seven inbound and outbound branches. An innovative design was developed for a 2.7-km section of a hybrid tunnel configured with a NATM tunnel at level -1 and a pile diaphragm walls at level -2.

SYSTRA has been in charge of the D&B services, including detailed engineering and technical assistance for the latter construction. The project is not only a great example of innovation but also sustainable design by recycling more than 2.3mln kg of steel and reusing of 1,800,000 tonnes of excavated material.

CONSTRUCTION:
Completed in 2022



CHILE

OWNER:

Sociedad Concesionaria Vespucio Oriente S.A. (ALEATICA & SACYR Concesiones Chile)

CONTRACTOR/CLIENT:

CVO (SACYR & OHLA)

PROJECT VALUE:

€828mln

OUR ROLE:

- Detailed Design
- Technical Assistance during construction



CONVENTIONAL



CUT AND COVER



Road



CAMPOLATTARO

Use of the Campolattaro reservoir and improvement of the water transport system in the city of Benevento

2019 - 2020

The Campolattaro reservoir, thanks to its position and dimensions, represents a strategic resource of water, able to satisfy the growing water requirements of the entire Campania region. To date, the reservoir lacks a water treatment plant and a hydroelectric power plant which could take advantage of the high difference in altitude which characterise the area. Also, there are no infrastructures able to bring this resource to potential users.

The diversion tunnel will be excavated, with a TBM EPB in complex geomechanical conditions where the presence of explosive and dangerous gas is evident.



ITALY

OWNER:

Acqua Campania

CONTRACTOR/CLIENT:

Vianini Lavori

PROJECT VALUE:

€136mIn

OUR ROLE:

- Feasibility Studies
- Preliminary Design of underground works
- Final Design

Water



CONSTRUCTION:
Completed in 2020



MECHANISED

ETIHAD PACKAGE 2D

Designing 9 tunnels in less than 6 months

2019 - 2022

Package D runs from Sharjah to Fujairah for 132km, providing connectivity to the Port of Fujairah in continuation of Stage Two Package C from the Dubai/Sharjah Border. Most of the alignment passes through the Hajar Mountains with numerous tunnels and structures. SYSTRA is the main designer for this joint venture. The sector HJR has 9 tunnels with a length between 293m and 1783m, with 4 tunnels of more than 762m that following the safety requirements impose supplementary galleries for evacuation. Excavation was proceeded in complex conditions including the UAE ophiolite and other requirements.

The biggest challenge in this project was the construction design of 9 tunnels in less than 6 months with high requirements for fire resistance. To fulfil this request, we provided 2 Full-time Teams (Paris & Dubai) of 12 Engineers.

Rail



CONSTRUCTION:
Completed in 2024



UAE

OWNER/CONTRACTOR:

China Railway Construction Corporation (CRCC) and National Projects and Construction (NPC) JV

CLIENT:

Etihad Rail

PROJECT VALUE:

€1,300mIn

OUR ROLE:

- Design



CONVENTIONAL

ŚWINOUJŚCIE TUNNEL

The longest road link tunnel in Poland excavated under the Świna river

2018 - 2022

The national speed-up road (GP class) will connect the islands of Wolin and Uznam in Świnoujście, on the section from Karsiborska street (approx. chainage km 0+000) in Uznam Island to the intersection between Duńska and Fińska street (approx. chainage km 3+200) in Wolin Island with a total length of approx. 3.2km.

The development of national road includes the construction of a tunnel with full-face mechanised excavation by a large diameter (13.46m) Slurry TBM under Świna river, for a length of approx. 1.44km, including access roads to the tunnel with two ramps built with open trench and cut and cover tunnel method on the island of Uznam and Wolin Island.



POLAND

OWNER:

Gmina Miasto Świnoujście

CONTRACTOR/CLIENT:

PORR and Gülermak JV

PROJECT VALUE:

€150mln

OUR ROLE:

- Final Design
- Detailed Design
- TBM Follow up during construction



MECHANISED



CUT AND COVER

CONSTRUCTION:
Completed in 2024

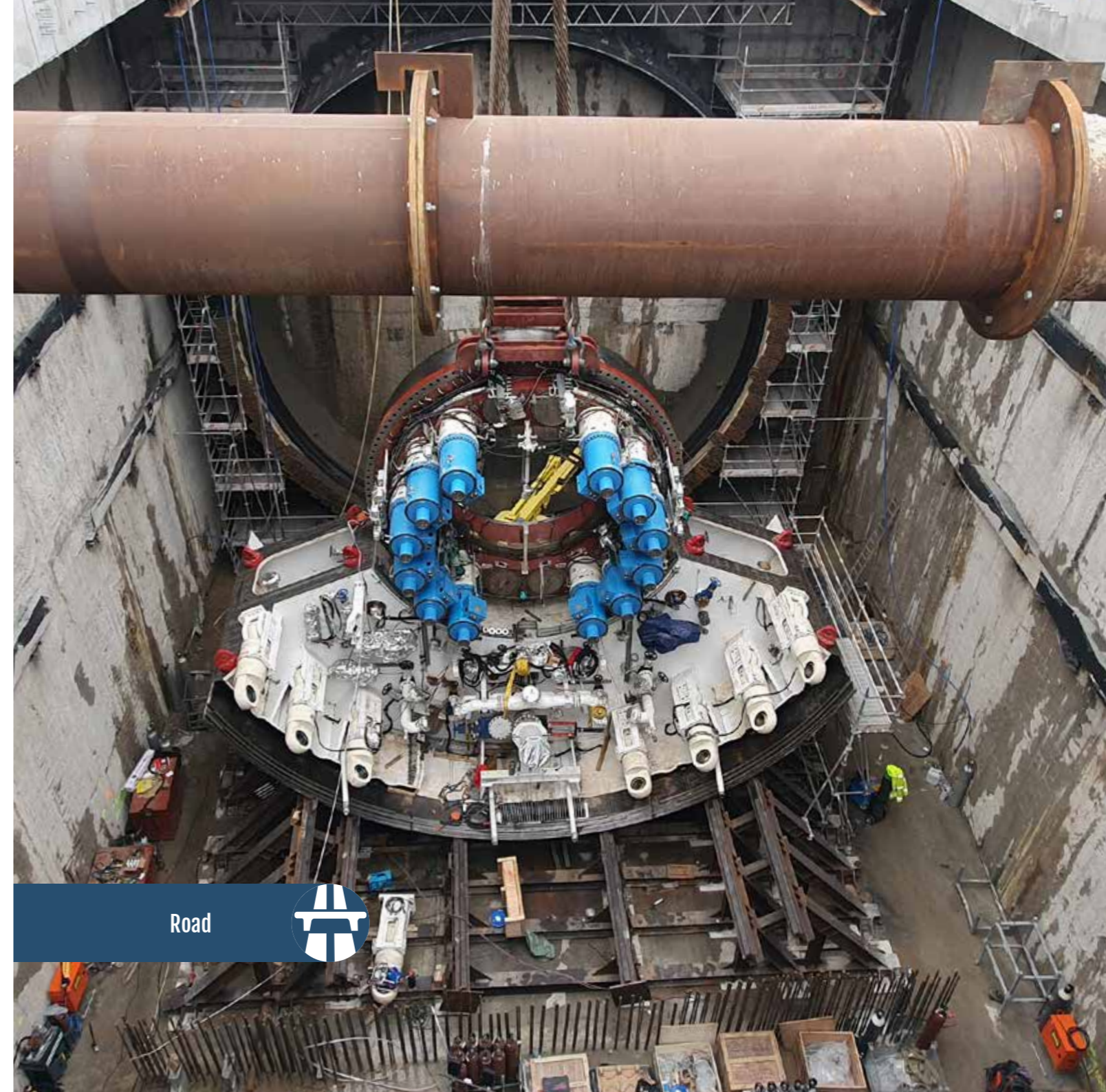

GRAND PARIS EXPRESS LINE 16

Very deep excavation with diaphragm walling techniques

2019 - Ongoing

The Line 16 lot 2 involves the construction of 11km of tunnels, 4 underground stations and 11 emergency/ventilation shafts. The tunnels will be excavated by two tunnel boring machines and the stations will be constructed using diaphragm walling techniques with depths down to 66m.

The project will cross challenging ground conditions such as high groundwater pressures, swelling clays and karstic features. The Clichy Montfermeil Station is located in a dense urban environment with very limited space available. To overcome these difficulties a peanut shaped box has been proposed to cater for the limited space and reduce the ground deformations on the neighbouring buildings.

The interior of the station is arranged on 4 floors and includes a shaft of light making the design of the civil works all the more complex. The ventilation shaft is a 14m diameter and 38m deep shaft constructed with diaphragm walling techniques.

CONSTRUCTION:
Expected completion in 2026



FRANCE

OWNER:
Société du Grand Paris

CONTRACTOR/CLIENT:
Webuild and NGE JV

PROJECT VALUE:
€ - confidential

OUR ROLE:

- Construction Design
- Independent Check



MECHANISED



CONVENTIONAL

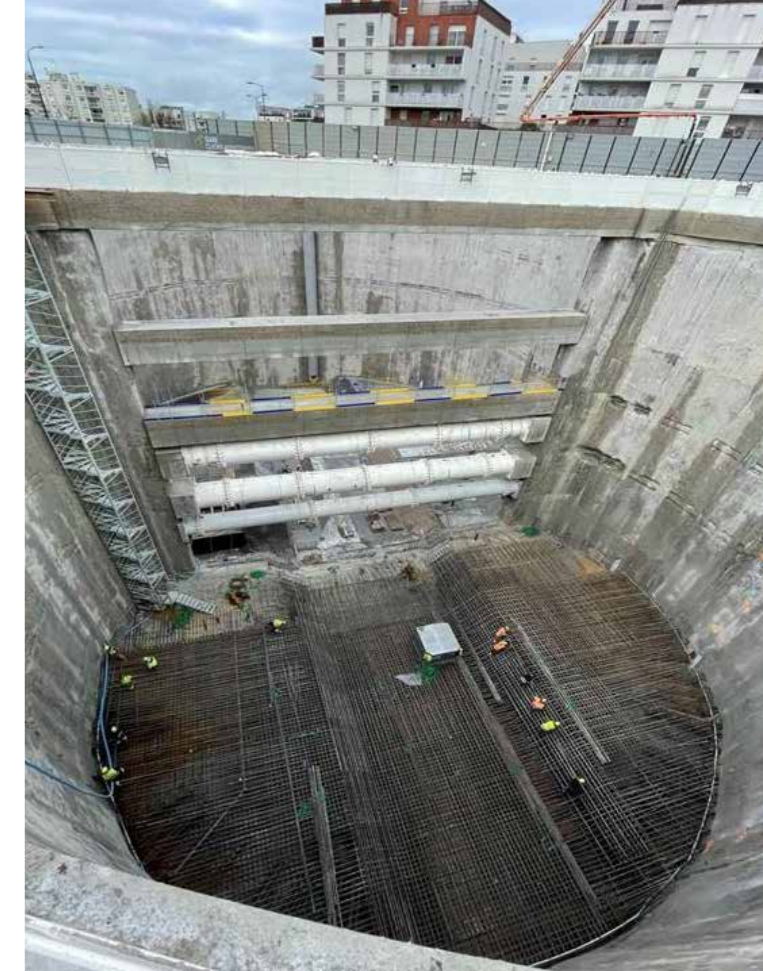

Metro



TURKISH STATE RAILWAYS

Multiple construction within highly urbanised zones and high seismicity

2011 - 2021

We are the designer of more than 850km of the most important and complex TCDD railway lines as Ankara Sivas, Toprakkale-Bahçe and Uşak Eşme. Around 180km of tunnel design is performed for Turkish State Railways, of which 100km are High Speed Railway Lines.

HSR requirements for alignments result in long tunnel excavations in highly urbanised zones with difficult ground conditions and high seismicity. Providing mechanised excavation methods and implementing new conventional excavation technologies to Turkish State Railways.



OWNER/CLIENT:
Turkish State Railways (TCDD)

PROJECT VALUE:
€ - confidential

- OUR ROLE:**
- Preliminary Design
 - Detailed Design
 - Design Verification
 - Technical Assistance to construction works



MECHANISED



CONVENTIONAL



CUT AND COVER

CONSTRUCTION:
Completed in 2021



FRÉJUS TUNNEL SAFETY GALLERY

Excavation of associated structures while keeping the tunnel in operation

2008 - 2025

The project included the excavation of a 13km tunnel, parallel to the existing cross-border tunnel to convert the single tube Fréjus tunnel into twin tubes designed for unidirectional traffic. The excavation of the safety gallery, shelters and associated structures were done while keeping the tunnel open to road traffic with a careful monitoring of vibrations on tunnel structure.

The first 650m of the gallery on the French side were excavated using the NATM method, a hard rock TBM with shield was then used to bore the tunnel southwards with a maximum overburden of 2,000m. On the Italian side, the construction of new multifunctional buildings adapted to the needs of the rescue, management and maintenance services.

OUR ROLE:

- General Consultant
- Project Manager
- Construction Management
- Project Management Consultant
- Design Engineering Supervision

CONSTRUCTION:
Completed in 2025



OWNER/CLIENTS:

Société Française du Tunnel Routier de Fréjus (SFTRF) and Società Italiana Traforo Autostradale del Fréjus (SITAF)

CONTRACTOR:

ITALIAN SIDE

Itinera, Mattioda and Razel-Bec

FRENCH SIDE

Razel-Bec and Bilfinger Berger

PROJECT VALUE:

€550mln



Road



CATANIA METRO LINE EXTENSION

Mixed conventional and mechanised tunnel excavations applied

2016 - 2020

This project entails the extension of the Catania Circumetnea metro, which is partly operating and partly under construction, in Catania's urban area. This infrastructure has unique technological characteristics and represents one of the most interesting European urban interventions, being used by more than 3,400,000 passengers a year.

The tunnel, hosting two railway tracks, was designed providing a mix between conventional and mechanised excavation techniques. Lot Nesima-Misterbianco and lot Stesicoro-Airport include 5 stations, 3.5km of tunnel and 13 ventilation openings.

The design included the Building Risk Assessment (BRA) and the geotechnical monitoring, inside and outside the tunnel.



OWNER:
Ferrovia Circumetnea

CONTRACTOR/CLIENT:
CMC di Ravenna

PROJECT VALUE:
€135mln

OUR ROLE:

- Detailed Design
- BIM Design
- Technical Assistance during construction



CONSTRUCTION:
Ongoing

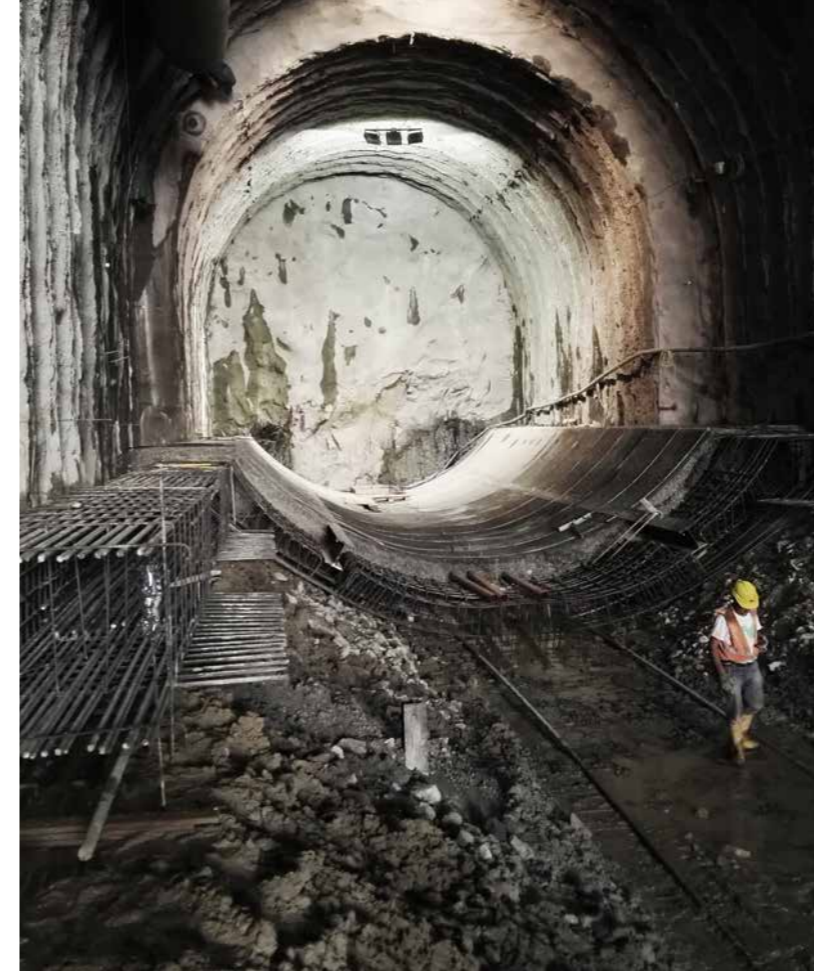

LEGACY WAY

Reuse of 125,000 tonnes of excavated material

2012 - 2015

Legacy Way is a motorway link which connects the Western suburbs of Brisbane to the central business district. The 4.6km twin bore tunnel won international recognition by being awarded the ITA Major Tunnel Project of the year in 2013.

SYSTRA provided delivery services for the Transcity Joint Venture for all the tunnels fit-out elements after tunnel excavation. This included innovatively reusing over 125,000 tonnes of TBM waste via a reconfigured TBM conveyor taking 10,000 heavy vehicles from local streets. The team was also key to the development and implementation of an innovative precast smoke duct solution.



OWNER/CLIENT:
Brisbane City Council/Queensland Government

CONTRACTOR:
Transcity JV (Acciona, Ghella, BMD)

PROJECT VALUE:
€920mln

OUR ROLE:
▪ Construction Delivery Support



CONSTRUCTION:
Completed in 2015



CABANASAS MINE

Severe squeezing and creeping during the excavation of the ramp causing significant deformation

2015 - 2020

The Cabanastas mine located in Súria, Barcelona region is a potash and salt mine. A second transportation ramp of 5km (19% inclination) at the maximum depth of 915m was built to expand the mine and to increase its extraction capacity. The section of the ramp allowed the installation of a belt and crossing of transport equipment during its excavation.

SYSTRA was responsible for the detailed design of the excavation, support and lining of the ramp, as well as the technical assistance during construction. Severe squeezing and creeping occurred during the excavation of the ramp after reaching 600m depth which caused a deformation ranging from 4cm (0.5%) to 80cm (8.5%) with creep velocities reaching 0.5mm per day. A sequential application of support elements in order to generate a yield response of the support was adopted, involving also a final shotcrete lining (SCL).



OWNER/CLIENT:
ICL Iberia

CONTRACTOR:
Ferrovia and Copisa JV, OSSA

PROJECT VALUE:
€160mln

OUR ROLE:
▪ Detailed Design
▪ Technical Assistance during construction



CONSTRUCTION:
Completed in 2020



BUCHAREST METRO LINE 5

Tunnelling right underneath an operated metro station

2009 - Ongoing

The route of line 5 has two branches on the west side, and interconnects with 2 of the other 4 lines of the metro network. Journey times from terminal to terminal will be reduced from 32 minutes to just 12 minutes.

The main challenge for this project of 6.9km twin-tunnel was tunnelling in urban environment and beneath the slab of an operated metro station at 1.2m distance. For that reason, multiple solutions were implemented with Building Risk Assessment at the centre of all the project phases. During the excavation process special EPB follow-up procedures were conducted with counter-measures in case of adverse structure behaviour.



OWNER/CLIENT:
METROREX

CONTRACTOR:
Astaldi, FCC Construcción, UTI Grup and Activ Group Management

PROJECT VALUE:
€628mln

OUR ROLE:

- Assistance to the client
- Consultancy services
- Works Supervision



CONSTRUCTION:
Completed in 2020



TUNNEL T1 DJEBEL EL OUAHCH

Challenging restoration of a collapsed tunnel

2017 - Ongoing

In the East section, at Djebel El Ouahch, starts the double-bored tunnel T1 Djebel dug with traditional techniques. The motorway project crosses Algeria parallel to the Mediterranean coasts. The highway connects the Tunisian border near the city of El Kala with the border with Morocco near Maghnia, passing close to the main Algerian cities of the north.

This tunnel rehabilitation operation of the east-west motorway is not complete yet for several reasons related to the complexity of the relief which constitutes a real danger for the workforce. The tunnel route meets complex geological conditions with predominance of clays. In accordance with the implementation of a schedule set by Cosider technicians take into consideration the reservations and solutions proposed in the conducted study, noting that security, protection, and technical intervention measures have been taken to accelerate the work.

CONSTRUCTION:
Ongoing



ALGERIA

OWNER:

Algérienne des Autoroutes (ADA)

CONTRACTOR/CLIENT:

Cosider Travaux Publics

PROJECT VALUE:

€56mln

OUR ROLE:

- Geological Campaign definition
- Detailed Design
- Technical Assistance during construction
- Monitoring Follow up



CONVENTIONAL

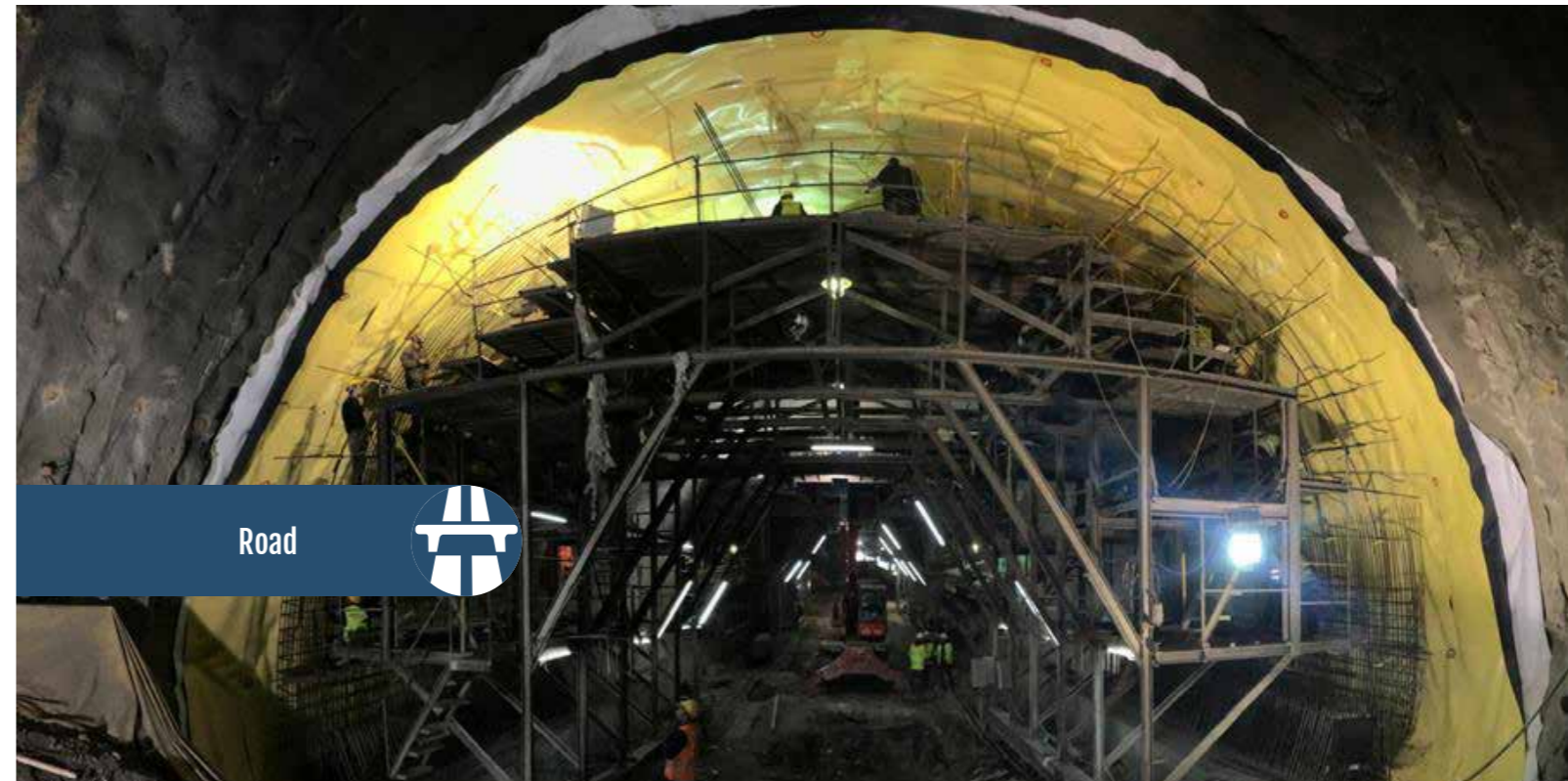

Road



FLORENCE HIGH-SPEED RAILWAY LINK

Stringent specifications on settlements due to historical monuments

2005 - 2009

The Florence High-Speed Rail project is part of the complex retrofit infrastructure program of the high-speed railway network that will run between Milan and Naples in Italy. The project has a total length of 16km and is mainly characterised by three functional components: the underpass, which is composed by 5km twin-bored tunnels (for a total length of 10km), constructed using a TBM machine which has a diameter of 9.4m, and by two SEM tunnels; the new Belfiore underground station, constructed with the top-down technique; and the overpass, which facilitates rail traffic between the two stations of Firenze Castello and Firenze Rifredi.

The new underground line crosses the city centre of Florence, running under more than 200 historical buildings (e.g. a 16th Century fortress). That is why particular attention was paid to design passive and active protection measures (e.g. DSM, soil freezing technique).

CONSTRUCTION:
Ongoing



OWNER:
Italferr

CLIENT:
Nodavia S.c.p.A. (General Contractor)

PROJECT VALUE:
€+1bil

OUR ROLE:
▪ Detailed Design



GRAND PARIS EXPRESS LINE 14 NORTH & SOUTH EXTENSION

The reduction of energy consumption and GHG emission

2007 - Ongoing

The southern extension (13.8km tunnel and 7 stations) will connect Olympiades, the current terminus of Line 14, to the Paris Orly International Airport. During construction the TBM crossed the airport's taxiway and the new passenger interchange station.

The North (5.8km tunnel and 4 stations 20m to 30m depth) is intended to decongest the over-crowded line 13 at its northern side. For two of the Metro stations-Porte de Clichy and Mairie de Saint-Ouen, the reduction of energy consumption and GHG emission was designed with the use of geothermal energy integration. Moreover, due to difficult ground conditions and groundwater, the continued implementation of ground freezing was necessary to proceed the excavation of the station at Porte de Clichy and Clichy-Saint-Ouen.



NORTH/SOUTH

OWNER/CLIENT:

Régie Autonome des Transports
Parisiens (RATP)

OUR ROLE:

- Infrastructure Design
- Construction Management Contracts
- Detailed Design

PROJECT VALUES:

€ - confidential



CONSTRUCTION:

NORTH: completed in 2021

SOUTH: completed in 2024

NORTH

CONTRACTOR:

Lot 01: Eiffage Travaux Publics and
Razel-Bec JV

Lot 02: Bouygues Travaux Publics,
Soletanche-Bachy, Soletanche-Bachy
Tunnels and CMS Bessac JV

Lot 03: Spie Batignolles TPCI,
Vinci construction, Dodin Campenon
Bernard, Botte Fondations ans Spie
Fondations JV

Lot 04: NGE, Demathieu Bard, Guintoli,
GTS, Franki and Atlas JV

SOUTH

CONTRACTOR:

Lot GC01: Léon Grosse and
Soletanche-Bachy JV

Lot GC02: Vinci, Spie Batignolles and
Botte Fondations JV

Lot GC03: Razel-Bec, Eiffage Travaux
Publics and Sefi JV

Lot GC04: NGE and Salini JV



PARIS METRO LINE 4 EXTENSION

Metro line extension in a very congested urban environment

2006 - 2022

The project included the design and construction management of 3 new stations, 1 maintenance workshop, 5 shafts. This project involves the creation of a 3.3km long twin-track tunnel, a rear station tunnel for train turning back, stabling, maintenance and washing, three additional stations with 95m long platforms, stabling tracks, pit tracks plus other auxiliary structures (ventilation, rectifier station, emergency services access point). The metro line 4 is completely underground, of which 30% is realised in a cut and cover trench, while conventional tunnelling methods (NATM) are used for the remaining civil engineering works.

SYSTRA supervised the entire southern extension, which was marked by the major challenge of integrating the works into the urban environment during construction, in order to cause as little disruption as possible to the lives of residents. Another challenge, a structural one, was to consolidate the galleries of the old Paris limestone quarries before building the tunnels.

CONSTRUCTION:
Completed in 2022



OWNER/CLIENT:
Régie Autonome des Transports
Parisiens (RATP)

CONTRACTOR:
Razel-Bec
Spie Batignolles and Dodin JV
Demathieu Bard and NGE JV

PROJECT VALUE:
€ - confidential

- OUR ROLE:**
- Preliminary Design
 - Detailed Design
 - Construction Supervision
 - Commissioning for civil works and secondary works



FORTEZZA-PONTE GARDENA

Geological conditions with weak rocks under great depth with possible squeezing phenomenon

2021 - Ongoing

The project is comprising of double railway tunnels Scaleres (15.4km) and Gardena (6.3km), two single interconnections railway tunnels northside (2.1km) and southside (3.2km), 4 intermediate access tunnels, Forch (1.4km), Albes (0.7km), Chiusa (1.8km) and Funes (0.5km). 70% of the HSR lines shall be bored through the mechanised system.

The challenges of the project do not only include difficult ground conditions but also underpasses of A22 highway (one of the most important commercial axes within Europe) with approximately 50,000 vehicles per day. Moreover, tunnels will cross an existing railway between Verona and Munich with an operational traffic of 280 trains per day. The distance between tunnel crown and railway is about 4m.



OWNER:
Rete Ferroviaria Italiana (RFI)

CONTRACTOR/CLIENT:
Webuild and Implenia JV

PROJECT VALUE:
€1.08bln

OUR ROLE:

- Detailed Design
- BIM Design
- MEP Design
- Technical Assistance during construction



CONSTRUCTION:
Expected completion in 2030

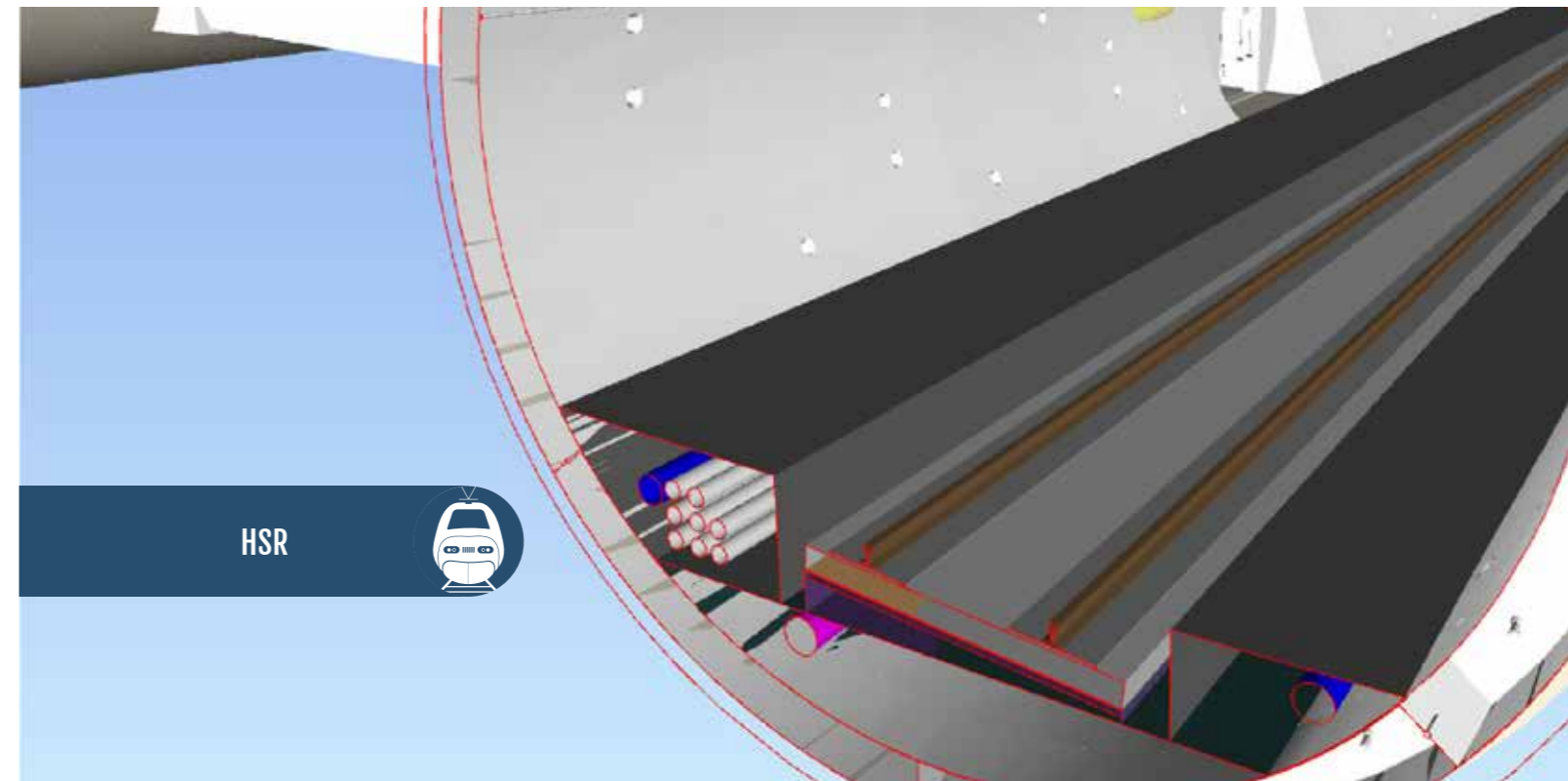
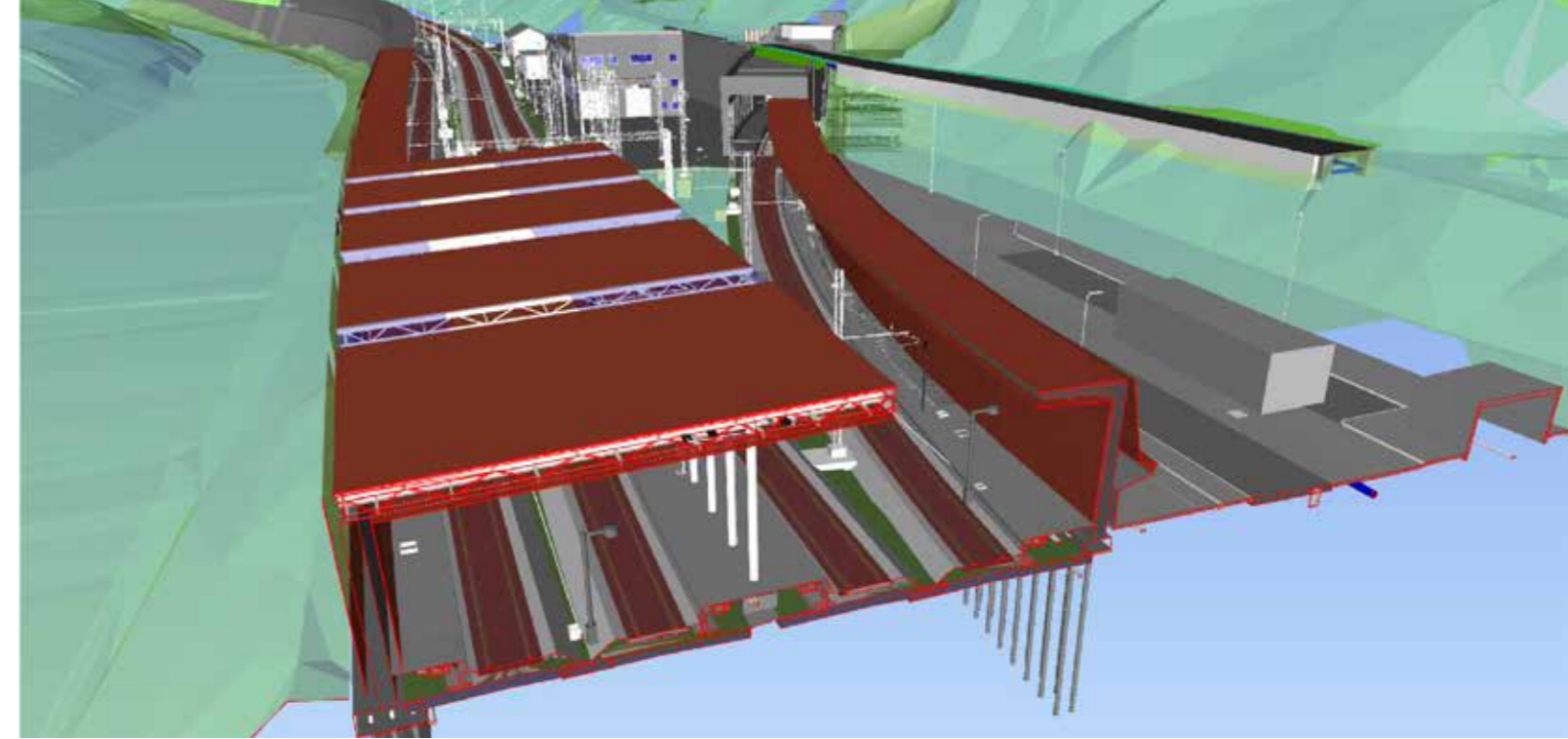

SYSTRA

Graphic Designer: Jennifer Cucchiara - SYSTRA

Finished printing: 2026

L'ENCRIER

19, rue Michel de l'Hospital

92130 Issy-les-Moulineaux, France

IMAGE COPYRIGHT:

3D RENDERINGS: ©SYSTRA

TUNNEL EURALPIN LYON TURIN (TELT) BASE TUNNEL: ©*Tunnel Euralpin Lyon Turin (TELT- SAS)*

WEST GATE TUNNEL PROJECT: ©*Copyright West Gate Tunnel Project*

©Copyright SYSTRA, April 2026

AUSTRALIA

Level 15, Chifley Tower
2 Chifley Square, Sydney NSW 2000

CANADA

1100, boul. René-Lévesque
Ouest, 10e étage
Montréal (Québec) H3B 4N4

UNITED STATES

55 Broad Street, Fifth Floor
New York, NY 10004

POLAND

ul. Komandorska 12
50-022 Wrocław

INDIA

Tower-B, Vatika Mindscapes
Mathura Road, NH-2, Sector-27/D
Faridabad, Haryana 21013, New Dehli

SPAIN

Vallehermoso, 18
Local 28015, Madrid

FRANCE

72 Rue Henry Farman
75015 Paris

SOUTH KOREA

6F & 10F
623 Teheran-ro, Gangnam-gu
Seoul, 06173

UNITED KINGDOM

1 Carey Lane
EC2V 8AE London, England

REPUBLIC OF IRELAND

Riverview House
21-23 City Quay, Dublin 2

UNITED ARAB EMIRATES

Office No. 1904
AL Masraf Tower
Baniyas Road, Deira, Dubai

PERU

General Recavarren 111, of 301
Miraflores, Lima 18

ITALY

Via della Stazione 27
38123 Trento

NORWAY

Lilleakerveien 4A
Lysaker 0283 Oslo

SWEDEN

Mölnadalsvägen 24
412 63 Gothenburg

TÜRKIYE

Mahatma Gandhi Cad. 26/3
GOP, Ankara

BRAZIL

Rua Gomes de Carvalho 1510
18° andar Vila Olimpia
São Paulo, 04547-005

CHILE

Alfredo Barros Errázuriz 1960
7500521, Providencia, Santiago

SYSTRA

www.systra.com